

Foundation Specifications

for 4.9-Meter Earth Station Antennas



1.0 INTRODUCTION

1.1 This document specifies typical foundation characteristics, designs, requirements and dimensional specifications for the Kratos 4.9-Meter Earth Station Antennas.

2.2 Varying load conditions are dependent upon icing, incident angle of the wind and elevation/azimuth angles of the antenna. Foundation loading forces and moments for various elevation versus wind conditions are listed in Table 1.

2.0 FOUNDATION LOADING CHARACTERISTICS

2.1 Foundation loads are applied to the foundation pad as shown in Figure 1. Positive applied forces are in the direction of the X, Y, and Z coordinate axes.

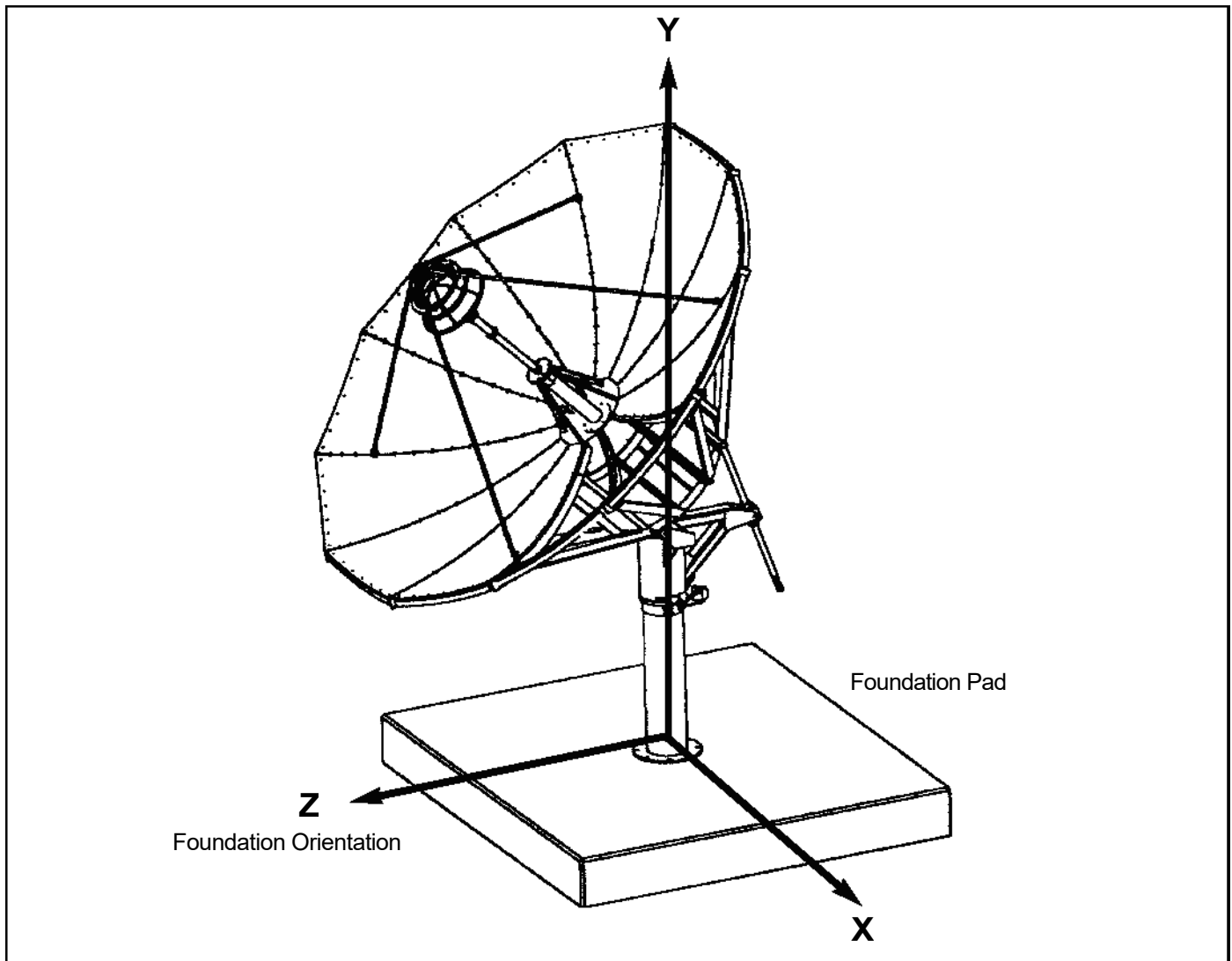

Figure 1

4.9M ESA Foundation Loads, wind speed = 125mph								
ε	α	Forces			Moments			
		Fx	Fy	Fz	Mx	My	Mz	
Elevation Angle (deg)	Wind Direction (deg)	Side (lbs)	Lift (lbs)	Drag (lbs)	Pitch (ft-lbs)	Yaw (ft-lbs)	Roll (ft-lbs)	
0	0	214	-171	-12630	-108826	801	-3529	
0	30	495	-214	-13123	-113889	6568	-5073	
0	60	-712	120	-11670	-104490	10114	5565	
0	90	-2213	197	1008	7879	-18339	19457	
0	120	-2771	85	3080	26763	-20987	23810	
0	150	-1565	0	6556	57432	-16638	13902	
0	180	-77	-111	7853	69704	529	1930	
20	0	205	-4880	-11887	-84695	393	-3068	
20	30	968	-4794	-12133	-88299	5600	-10338	
20	60	-951	-3828	-10880	-80322	8932	2588	
20	90	-2145	419	974	6519	-16812	22272	
20	120	-2786	795	2951	25666	-19838	28387	
20	150	-1805	1171	5826	53289	-15359	19671	
20	180	0	1436	7460	68970	-846	1269	
40	0	248	-8426	-9451	-49669	340	-2877	
40	30	-416	-7785	-9233	-49253	4318	-2015	
40	60	-1432	-5828	-7330	-44003	-2561	7442	
40	90	-2153	795	820	3927	-14280	20227	
40	120	-2761	1137	2344	20804	-16038	30245	
40	150	-1960	1718	4710	45617	-12573	23130	
40	180	-17	1957	5734	57253	409	976	
60	0	94	-10656	-6777	-12155	113	-1390	
60	30	-786	-8469	-6010	-18073	1026	185	
60	60	-1930	-4956	-3630	-19358	-7968	19444	
60	90	-2188	1008	521	469	-11804	27088	
60	120	-2250	1769	2118	16741	-10329	25170	
60	150	-1701	1316	3014	31565	-7974	19830	
60	180	-51	1393	3572	39307	-203	1079	
80	0	43	-3700	-2786	-19582	214	-1150	
80	30	-1358	-2982	-2591	-20820	-4705	13640	
80	60	-2201	-1384	-1212	-12467	-8959	26399	
80	90	-2068	1051	222	-2040	-8591	28100	
80	120	-2166	2435	1478	9899	-8336	26878	
80	150	-1368	2897	2506	21245	-5145	15850	
80	180	-34	2478	2606	22780	-58	525	

Table 1

3.0 ANCHOR BOLT REQUIREMENTS

3.1 Typical anchor bolt installation configurations and dimensions are shown in Figure 2.

3.2 Kratos Type 302689 Anchor Bolt Kit includes anchor bolts, alignment plates and required mounting hardware as shown.

4.0 FOUNDATION DESIGNS

4.1 The selected foundation for a particular site is dependent upon local conditions. Soil borings and foundation analysis should be performed by a qualified civil engineer.

4.2 A typical slab type foundation is shown in Figure 2. An enlarged copy of this design is available from Kratos on request. Refer to drawing number 240287.

5.0 FOUNDATION ORIENTATION

5.1 Proper foundation orientation is required to obtain the desired orbital arc coverage from a particular site location. The required azimuth and elevation angles of the antenna, relative to the mount must be determined to establish the appropriate foundation orientation. A specific foundation orientation requirement may be requested with the antenna as part of the installation package.

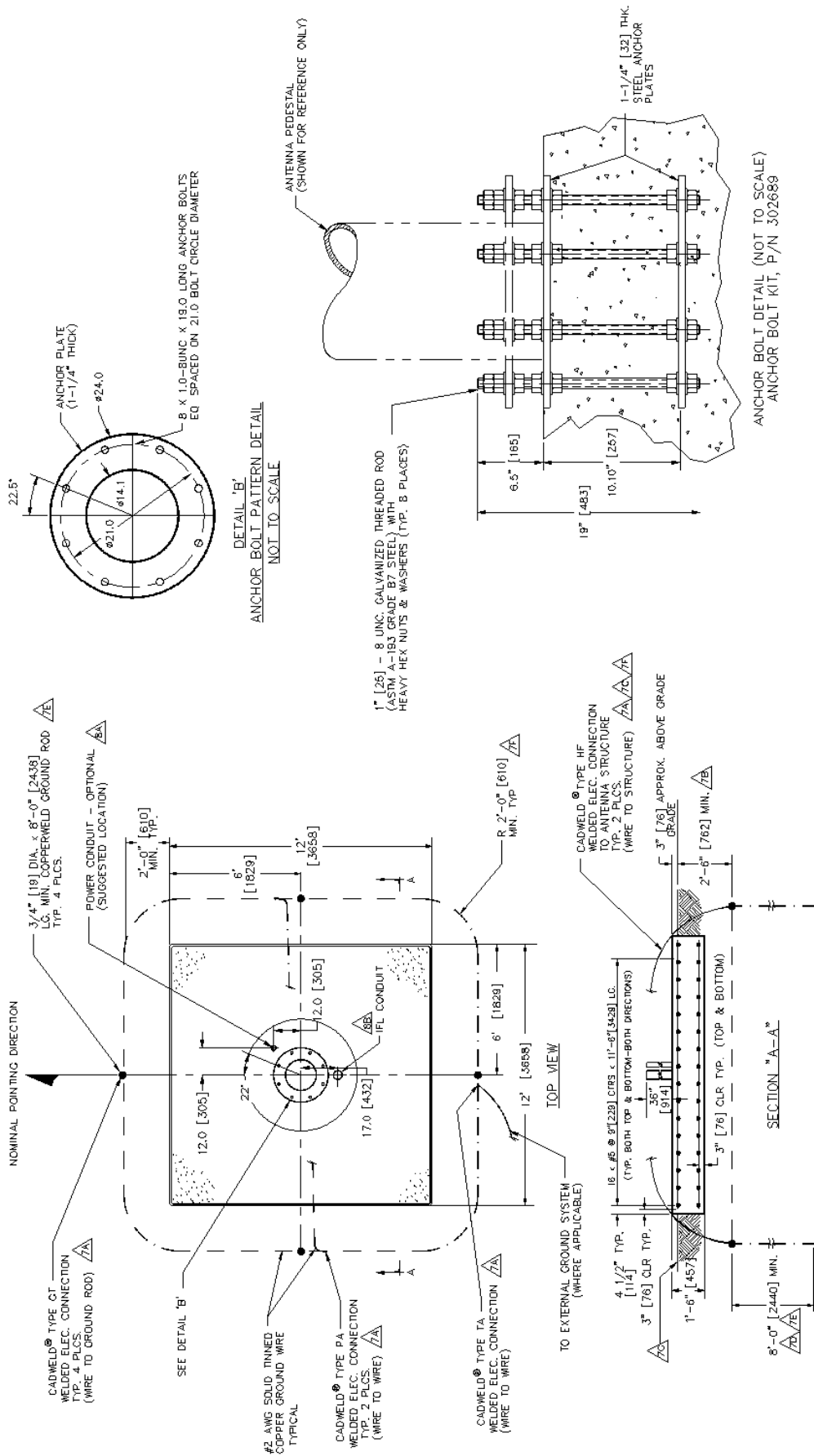

Figure 2

General Notes

1. Remove all burrs and sharp edges.
2. Dimensions apply before plating.
3. Interpret drawing per ANSI Y14.5M-1982.
4. Dimensions are shown in feet and inches. Dimensions in brackets [] are in millimeters.
5. A tolerance of $\pm 1/8$ " [3] applies to all anchor bolt layout dimensions.

6. Foundation Notes:

- A) This foundation is a typical design only. Certification of its suitability for a particular installation by a professional engineer is required prior to its use for actual fabrication.
- B) Contractor shall field verify all dimensions locating existing construction before fabrication of new construction begins.
- C) Concrete and related work shall be mixed, placed and cured in accordance with "Building Code Requirements for Reinforced Concrete" ACI 318-89 (Rev. 88) and "Specifications for Structural Concrete" ACI 301-84 (Rev. 88) publication SP-15 (88).
- D) Concrete for foundations shall develop a compressive strength of at least 3000 psi [211 kgf/cm²] in 28 days with a maximum slump of 3" [76] at time of placing.
- E) Reinforcing bars shall conform to ASTM A 615 [S1] grade 60 deformed type $F_y = 60000$ psi [4219 kgf/cm²].
- F) Unless otherwise noted, concrete cover of reinforcing bars shall conform to minimum requirements of ACI 318-89 (Rev. 88).
- G) Fabrication of reinforcing steel shall be in accordance with "Manual of Standard Practice for Detailing Reinforcing Concrete Structures" ACI 315-80 (Rev. 86).
- H) Provide $3/4$ " x 45° [19 x 45°] chamfer on all exposed concrete edges.
- J) Foundations have been designed to rest on undisturbed soil (per EIA-41 1-A and RS-222-D) with a minimum allowable net vertical bearing capacity of 2000 psf [9770 kgf/m²]. If undesirable soil conditions are encountered, the engineer shall be notified.
- K) Backfills shall be suitable excavated material or other suitable material compacted in 6" lifts to 90% of maximum density as determined by ASTM D1557.
- L) If this foundation is to be located in an area where annual frost penetration depth exceeds 15" [381], the local building code specifying a minimum required foundation depth should be consulted.

7. Grounding Electrode System Notes:

The grounding system shown represents the minimum requirements to achieve satisfactory grounding. Actual site conditions and soil resistivity levels will determine final grounding system design to comply with the following:

- A) All ground ring, ground rod and antenna structure connections to be EIRCO® products, Inc. Calweld® exothermic type welded electrical connections or equivalent.
- B) Ground rods shall be driven to a depth below permanent moisture level (minimum depth shown) as dictated by geographical location.
- C) The antenna structure shall be connected to a grounding electrode system consisting of a number of interconnected ground rods. The system shall meet the requirements of the Underwriters' Laboratories Publication No. ,UL96A for Lightning protection.
- D) The grounding electrode system to earth resistance shall not exceed 10 Ohms, measured with a Biddle 3 terminal device or equivalent. The grounded conductor (neutral) supplied to all ac equipment on the antenna structure should be disconnected before taking measurement.
- E) Actual site conditions may require longer ground rods, additional ground rods and/or land fill additives to reduce soil resistivity levels.
- F) Avoid sharp bends when routing grounding wire. Grounding wires to antenna structure to be run as short and straight as possible.
- G) Final grade directly above grounding electrode system to be water permeable.

8. Power/IFL Conduit Notes:

- A) Electrical power - Drawing depicts suggested location for electrical power conduit to antenna. Size, type and depth to bury conduit to be determined by customer in compliance with local codes. Direction to route conduit to be determined by the relative location of communications building/shelter. Power conduit to extend 6" (minimum) above surface of foundation slab. Open ends of conduit to be sealed to prevent moisture and foreign particle contamination. Customer to provide main load center assembly and over-current protection devices for electrical equipment. Mounting location of load center to be determined by customer in accordance with local codes.
- B) For routing IFL cables, 4" size conduit recommended. Type and depth to bury conduit to be determined by customer, in compliance with local codes. Location of conduit on foundation and direction to route conduit to be determined by location of communications building/shelter. Conduit to extend 36" (minimum) above surface of foundation slab. All bends to be large radius, maximum of two bends per run. Open ends of conduit to be sealed to prevent moisture and/or foreign particle contamination.

6.0 ANTENNA GEOMETRY

6.1 Figures 3 and 4 illustrate basic dimensional characteristics and azimuth adjustment range capabilities of the 4.9-meter antenna.

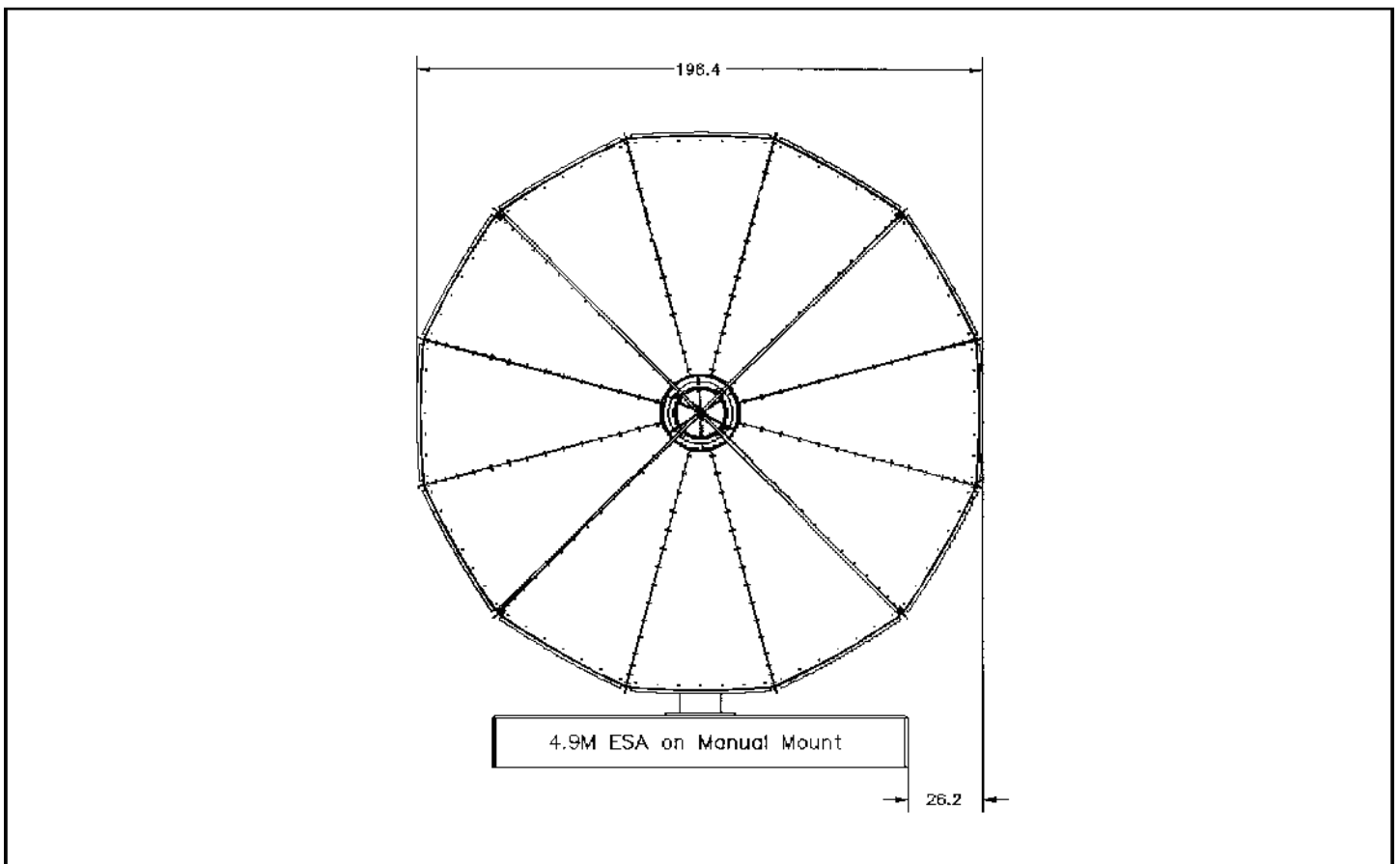
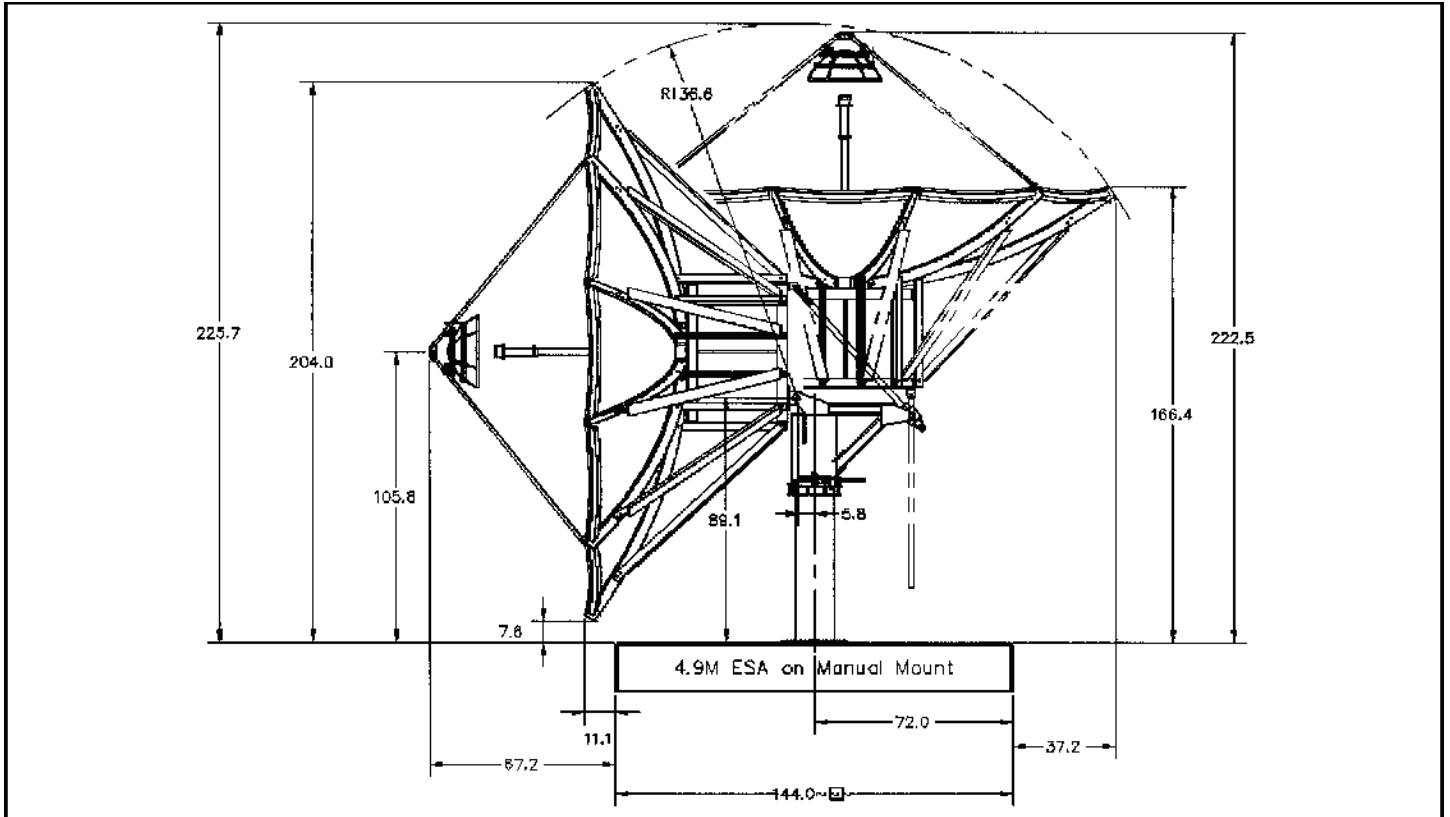

Figure 3

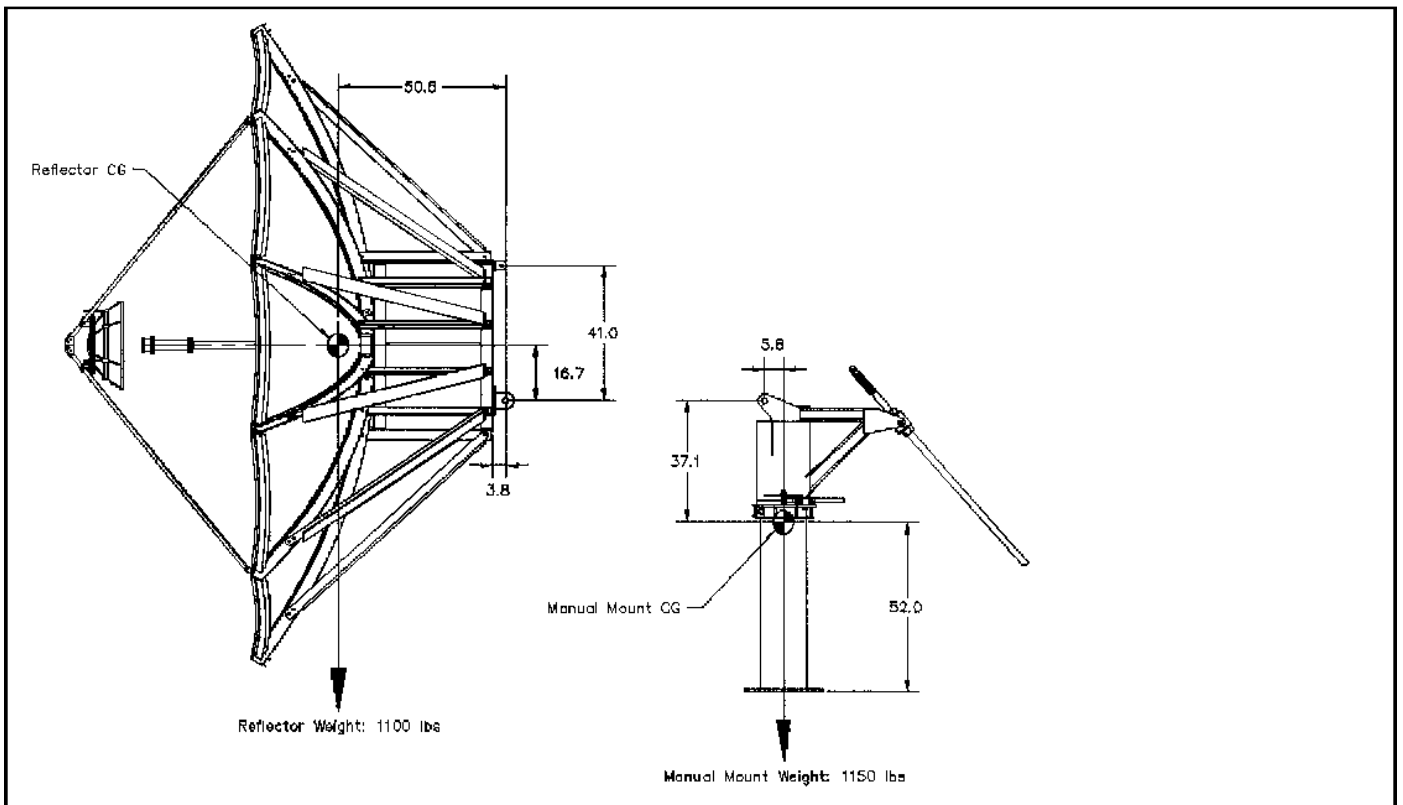
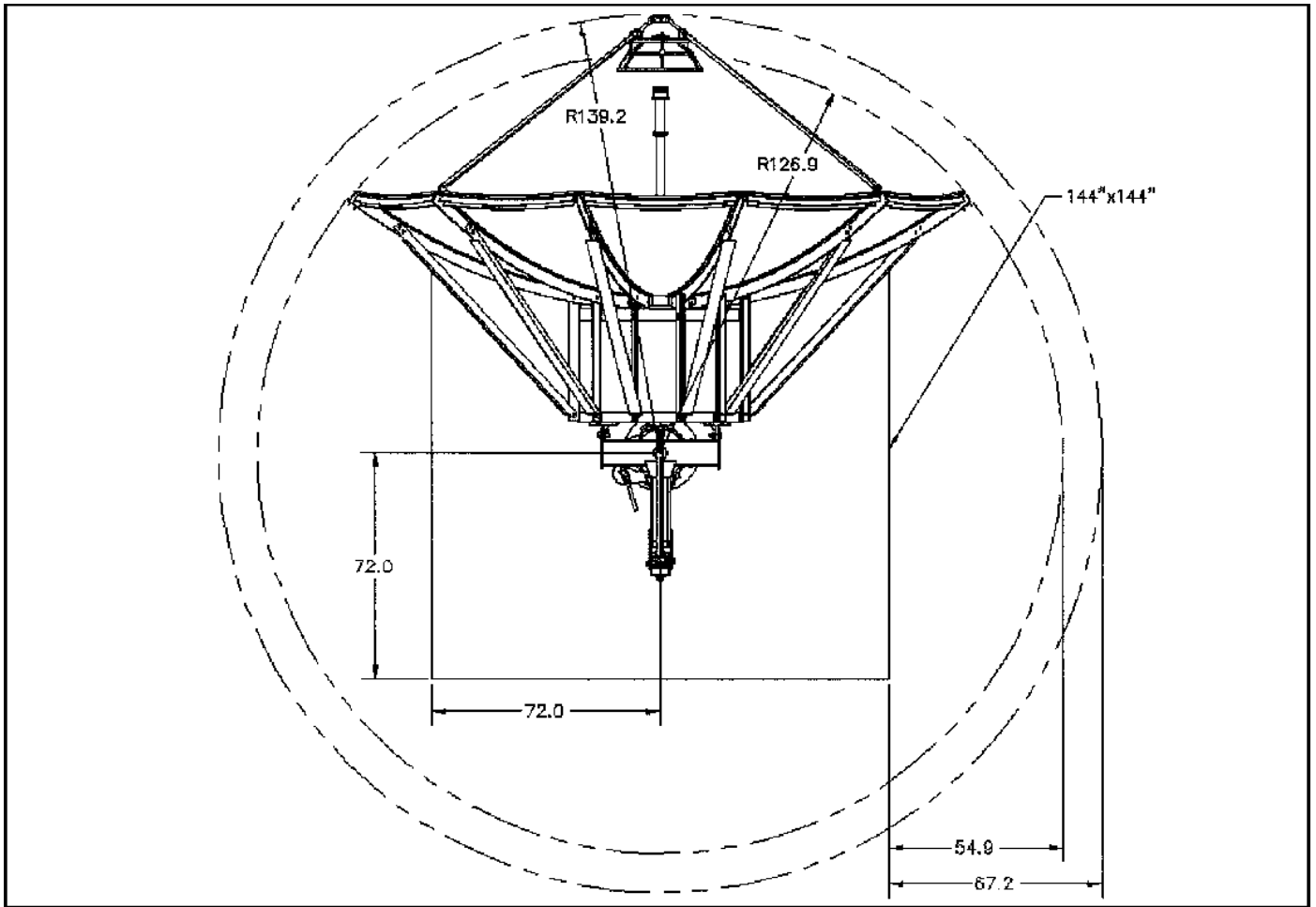
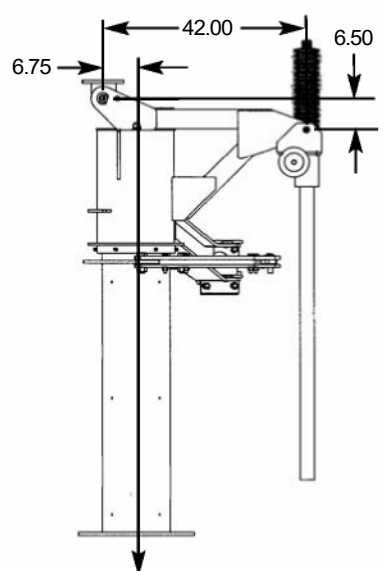
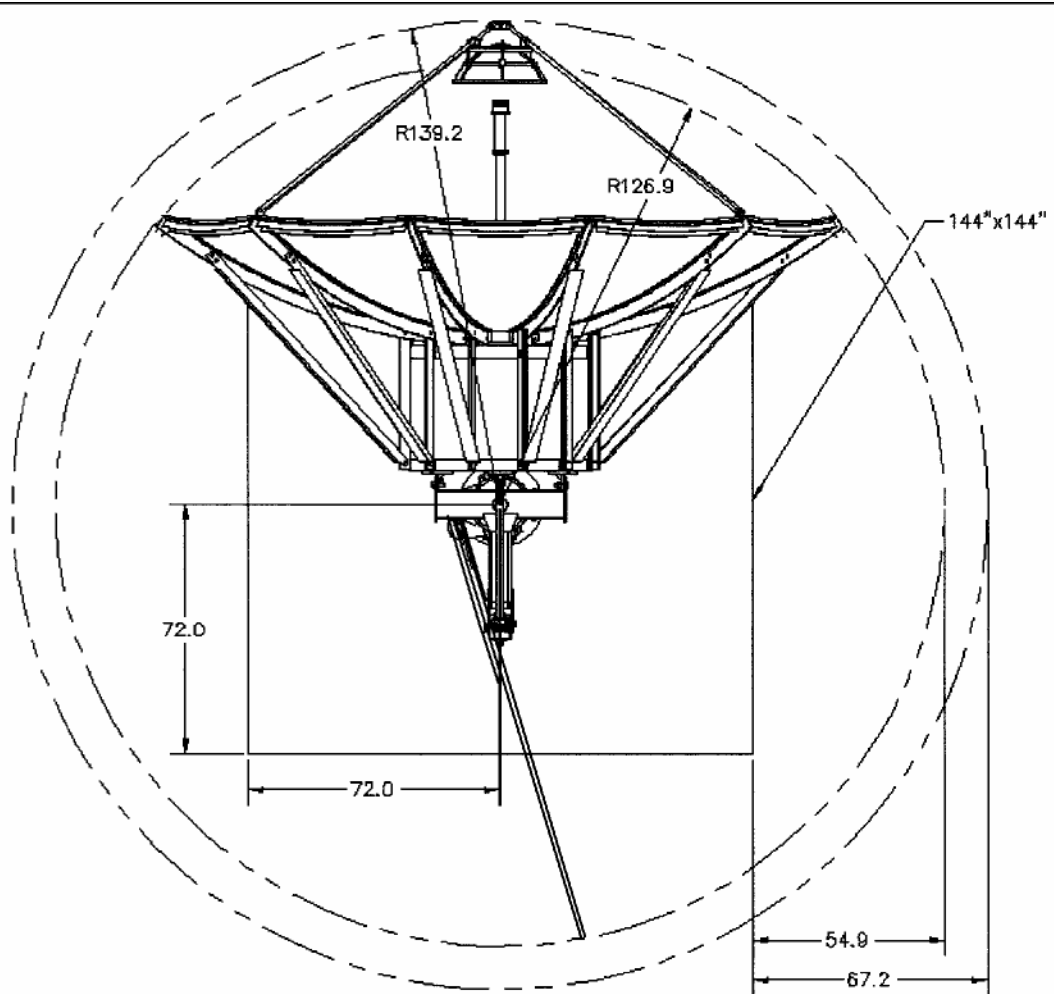

Figure 4



Motorized Mount Dimensions

Figure 5