

# Foundation Specifications

## for 3.5-Meter Earth Station Antennas



### 1.0 INTRODUCTION

1.1 This document specifies typical foundation characteristics, designs, requirements and dimensional specifications for the Kratos 3.5-Meter Earth Station Antennas.

### 2.0 FOUNDATION LOADING CHARACTERISTICS

2.1 Foundation loads are applied to the foundation pad

as shown in Figure 1. Positive applied forces are in the direction of the X, Y, and Z coordinate axes. The XYZ coordinate system is centered at the bottom of the pedestal base plate and center of the pedestal tube.

2.2 Varying load conditions are dependent upon icing, incident angle of the wind and elevation/azimuth angles of the antenna. Foundation loading forces and moments for various elevation versus wind conditions are listed in Table 1.

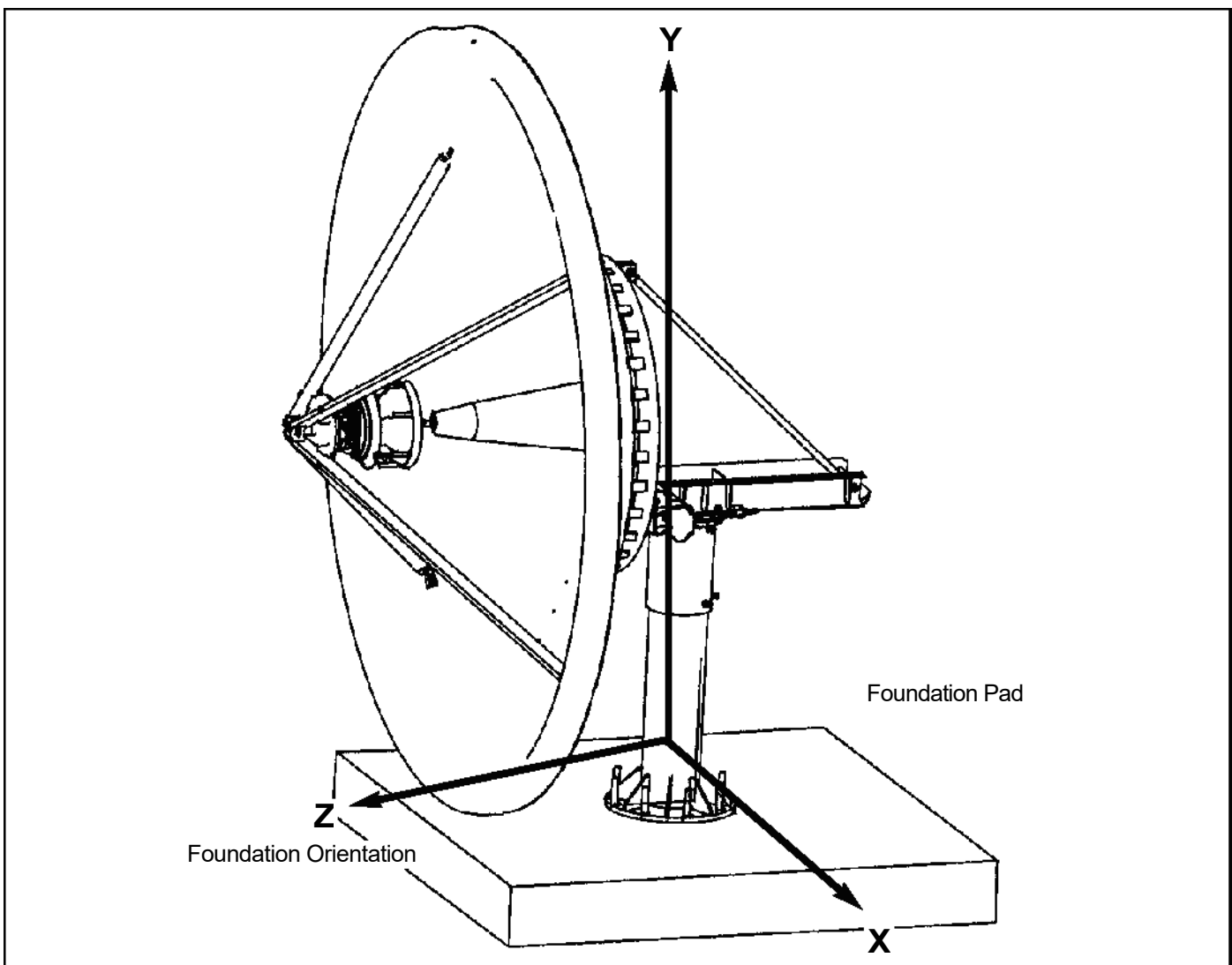

Figure 1

Foundation Loads For 150 MPH At Pedestal Mounting Point						
Elevation 0°						
Wind Angle	FX(lb)	FY(lb)	FZ(lb)	MX(in lb)	MY(in lb)	MZ(in lb)
0	0	-1,917	-8,732	-640,329	13	866
30	-280	-1,917	-8,252	-600,107	-33,228	21,949
60	-560	-1,917	-7,771	-559,850	-66,476	43,037
90	909	-1,917	888	93,203	105,056	-67,496
120	1,080	-1,917	2,554	219,338	124,130	-80,370
150	541	-1,917	4,162	338,593	62,160	-39,805
180	1	-1,917	5,769	457,813	167	775
Elevation 30°						
0	-33	-6,714	-7,005	-445,580	-3,174	5,074
30	-305	-6,587	-6,868	-440,658	-29,717	39,538
60	-334	-5,690	-5,596	-366,679	-32,873	43,373
90	909	-1,900	767	71,674	86,178	-112,882
120	1,013	-1,444	2,149	201,993	95,611	-125,697
150	571	-987	3,314	304,952	53,821	-70,406
180	18	-733	3,875	351,294	1,668	-1,379
Elevation 60°						
0	0	-9,343	-3,400	-166,421	-6	922
30	-192	-8,123	-3,008	-168,461	-10,371	31,961
60	178	-5,140	-1,723	-120,880	8,887	-26,677
90	909	-1,565	441	36,425	47,153	-142,760
120	887	-1,091	1,229	137,113	45,873	-139,055
150	585	-771	1,916	229,590	30,226	-91,370
180	0	-664	2,211	270,838	14	867
Elevation 80°						
0	-2	-4,161	-759	-96,470	-33	1,233
30	245	-3,776	-691	-91,630	3,962	-39,443
60	577	-2,750	-420	-63,370	9,411	-94,580
90	909	-1,393	151	9,788	14,898	-149,865
120	816	-1,200	657	91,284	13,356	-134,324
150	486	-1,062	1,051	154,948	7,969	-79,672
180	2	-1,013	1,202	179,369	41	592

Table 1

### 3.0 ANCHOR BOLT REQUIREMENTS

**3.1** Typical anchor bolt installation configurations and dimensions are shown in Figure 2.

**3.2** Kratos Type 302689 Anchor Bolt Kit includes anchor bolts, alignment plates and required mounting hardware as shown.

### 4.0 FOUNDATION DESIGNS

**4.1** The selected foundation for a particular site is dependent upon local conditions. Soil borings and foundation analysis should be performed by a qualified civil engineer.

**4.2** A typical slab type foundation is shown in Figure 2. An enlarged copy of this design is available from Kratos on request. Refer to drawing number 240350.

### 5.0 FOUNDATION ORIENTATION

**5.1** Proper foundation orientation is required to obtain the desired orbital arc coverage from a particular site location. The required azimuth and elevation angles of the antenna, relative to the mount must be determined to establish the appropriate foundation orientation. A specific foundation orientation requirement may be requested with the antenna as part of the installation package.

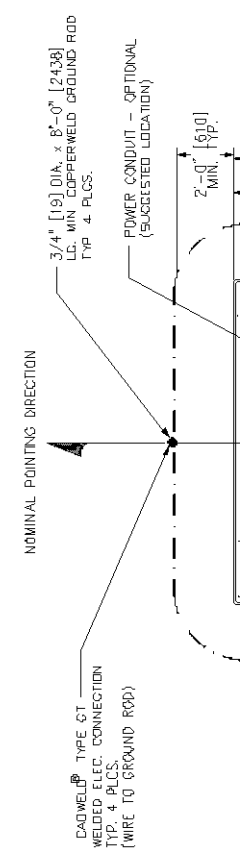
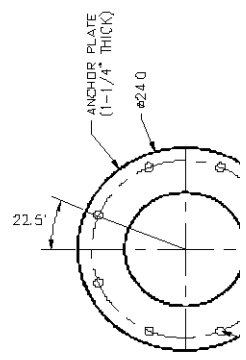

Figure 2  
3 of 6

## General Notes

---

1. Remove all burrs and sharp edges.
2. Dimensions apply before plating.
3. Interpret drawing per ANSI Y14.5M-1982.
4. Dimensions are shown in feet and inches. Dimensions in brackets [ ] are in millimeters.
5. A tolerance of  $\pm 1/8"$  [3] applies to all anchor bolt layout dimensions.

### 6. Foundation Notes:

- A) This foundation is a typical design only. Certification of its suitability for a particular installation by a professional engineer is required prior to its use for actual fabrication.
- B) Contractor shall field verify all dimensions locating existing construction before fabrication of new construction begins.
- C) Concrete and related work shall be mixed, placed and cured in accordance with "Building Code Requirement for Reinforced Concrete" ACI 318-89 (Rev. 88) and "Specifications for Structural Concrete" ACI 301-84 (Rev. 88) publication SP-15 (88).
- D) Concrete for foundations shall develop a compressive strength of at least 3000 psi [211 kgf/cm<sup>2</sup>] in 28 days with a maximum slump of 3" [76] at time of placing.
- E) Reinforcing bars shall conform to ASTM A 615 [S1] grade 60 deformed type  $F_y = 60000$  psi [4219 kgf/cm<sup>2</sup>].
- F) Unless otherwise noted, concrete cover of reinforcing bars shall conform to minimum requirements of ACI 318-89 (Rev. 88).
- G) Fabrication of reinforcing steel shall be in accordance with "Manual of Standard Practice for Detailing Reinforcing Concrete Structures" ACI 315-80 (Rev. 86).
- H) Provide 3/4" x 45° [19 x 45°] chamfer on all exposed concrete edges.
- J) Foundations have been designed to rest on undisturbed soil (per EIA-41 1-A and RS-222-D) with a minimum allowable net vertical bearing capacity of 2000 psf [9770 kgf/m<sup>2</sup>]. If undesirable soil conditions are encountered, the engineer shall be notified.
- K) Backfills shall be suitable excavated material or other suitable material compacted in 6" lifts to 90% of maximum density as determined by ASTM D1557.
- L) If this foundation is to be located in an area where annual frost penetration depth exceeds 15" [381], the local building code specifying a minimum required foundation depth should be consulted.

### 7. Grounding Electrode System Notes:

The grounding system shown represents the minimum requirements to achieve satisfactory grounding. Actual site conditions and soil resistivity levels will determine final grounding system design to comply with the following:

- A) All ground ring, ground rod and antenna structure connections to be EIRCO® products, Inc. Calweld® exothermic type welded electrical connections or equivalent.
- B) Ground rods shall be driven to a depth below permanent moisture level (minimum depth shown) as dictated by geographical location.
- C) The antenna structure shall be connected to a grounding electrode system consisting of a number of interconnected ground rods. The system shall meet the requirements of the Underwriters' Laboratories Publication No. UL96A for Lightning protection.
- D) The grounding electrode system to earth resistance shall not exceed 10 Ohms, measured with a Biddle 3 terminal device or equivalent. The grounded conductor (neutral) supplied to all ac equipment on the antenna structure should be disconnected before taking measurement.
- E) Actual site conditions may require longer ground rods, additional ground rods and/or land fill additives to reduce soil resistivity levels.
- F) Avoid sharp bends when routing grounding wire. Grounding wires to antenna structure to be run as short and straight as possible.
- G) Final grade directly above grounding electrode system to be water permeable.

### 8. Power/IFL Conduit Notes:

- A) Electrical power - Drawing depicts suggested location for electrical power conduit to antenna. Size, type and depth to bury conduit to be determined by customer in compliance with local codes. Direction to route conduit to be determined by the relative location of communications building/shelter. Power conduit to extend 6" (minimum) above surface of foundation slab. Open ends of conduit to be sealed to prevent moisture and foreign particle contamination.

Customer to provide main load center assembly and over-current protection devices for electrical equipment. Mounting location of load center to be determined by customer in accordance with local codes.

- B) For routing IFL cables, 4" size conduit recommended. Type and depth to bury conduit to be determined by customer, in compliance with local codes. Location of conduit on foundation and direction to route conduit to be determined by location of communications building/shelter. Conduit to extend 36" (minimum) above surface of foundation slab. All bends to be large radius, maximum of two bends per run. Open ends of conduit to be sealed to prevent moisture and/or foreign particle contamination.

## 6.0 ANTENNA GEOMETRY

6.1 Figures 3 and 4 illustrate basic dimensional characteristics and azimuth adjustment range capabilities of the 3.5-meter antenna.

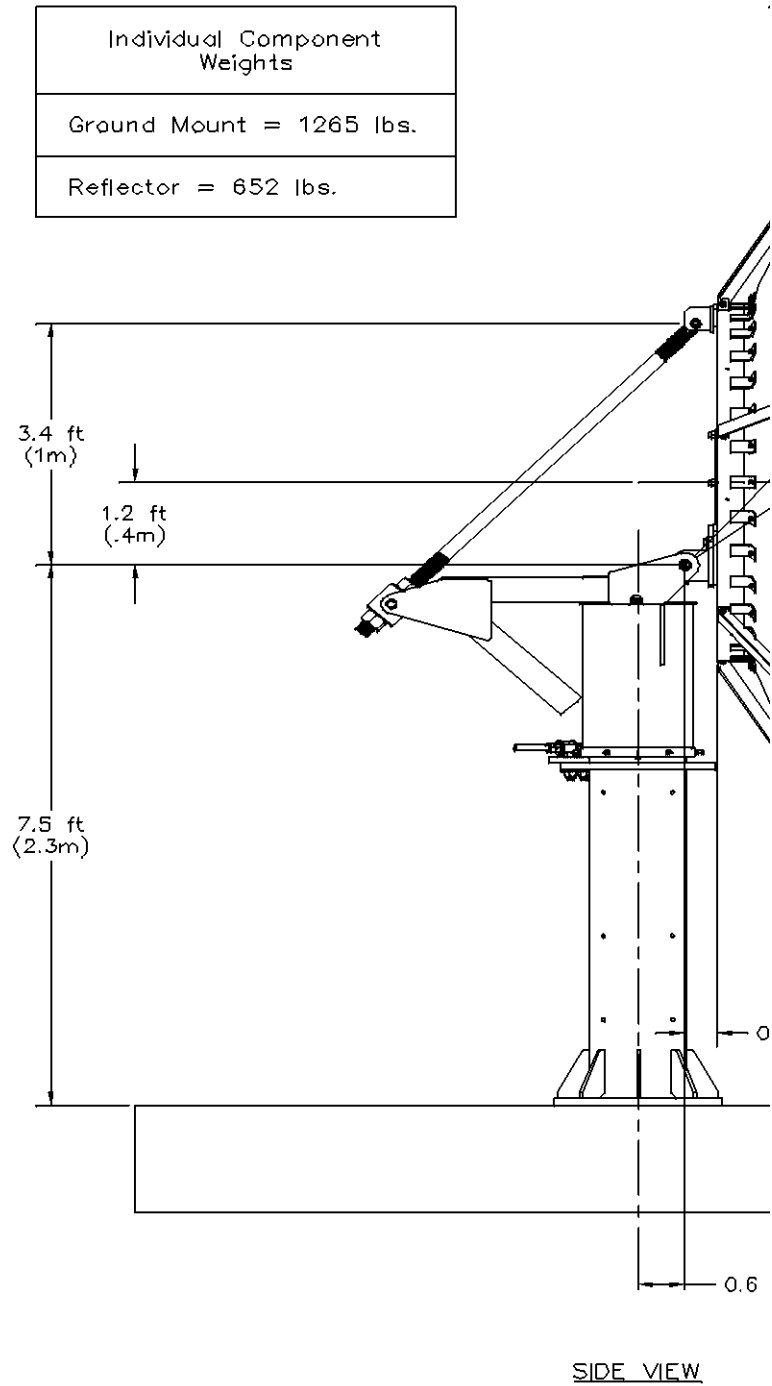

Figure 3

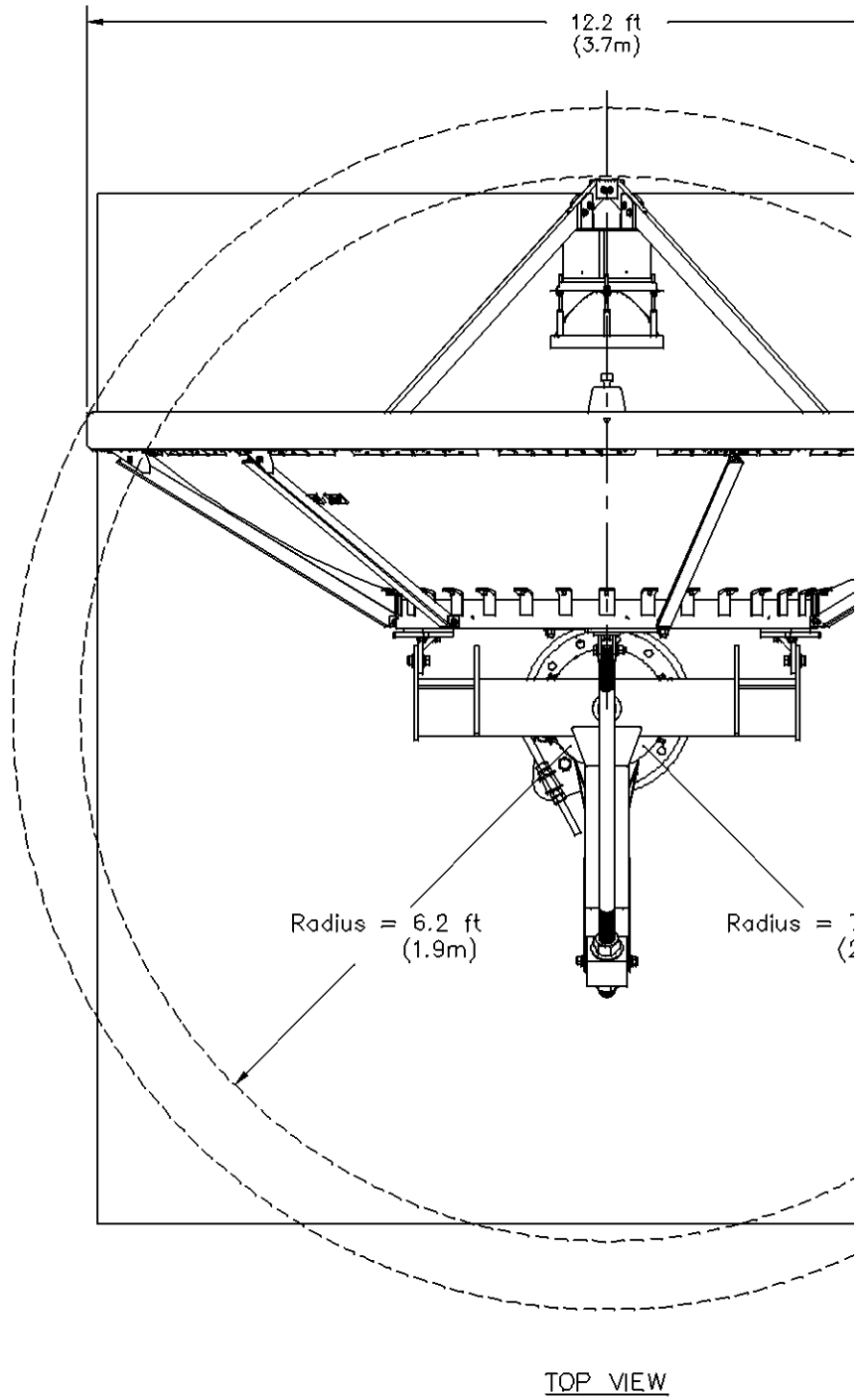

Figure 4