

Foundation Specifications

for 9.4-Meter Earth Station Antenna



Introduction

This document specifies typical foundation characteristics, designs, requirements, and dimensional specifications for the Kratos 9.4-Meter Earth Station Antenna.

Foundation Loading Characteristics

Foundation loads are applied to the foundation pad as shown in Figure 3a. Positive applied forces are in the direction of the X, Y and Z coordinate axes.

Varying load conditions are dependent upon incident angle of the wind and elevation/azimuth angles of the antenna. Foundation loading forces for various elevation/azimuth vs. wind conditions are listed in Table 1.

Foundation Designs

The selected foundation for a particular site is dependent upon local conditions. Soil borings and foundation analysis should be performed by a qualified civil engineer.

A typical slab type foundation design is shown in Figure 3b. A copy of this design is available from Kratos on request. Refer to Drawing 175365.

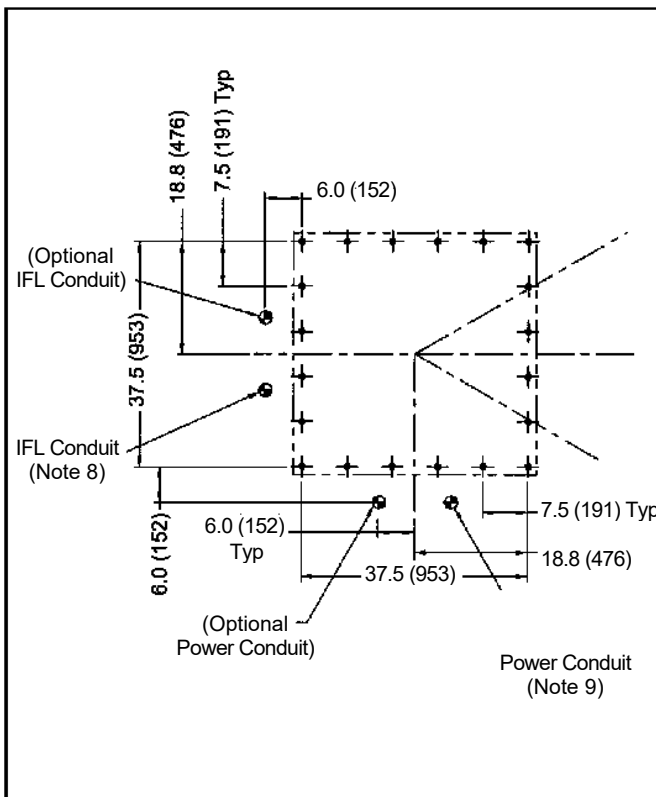

Figure 1

Anchor Bolt Requirements

A typical anchor bolt installation configuration and corresponding dimensions are shown in Figure 2.

Kratos Type 175370 Foundation Kit includes anchor bolts, alignment plates and required mounting hardware as shown in Figure 2.

Foundation Orientation

Proper foundation orientation is required to obtain the desired orbital arc coverage from a particular site location. The required azimuth and elevation angles of the antenna, relative to the mount, must be determined to establish the appropriate foundation orientation. A specific foundation orientation requirement may be requested with antenna as part of installation package.

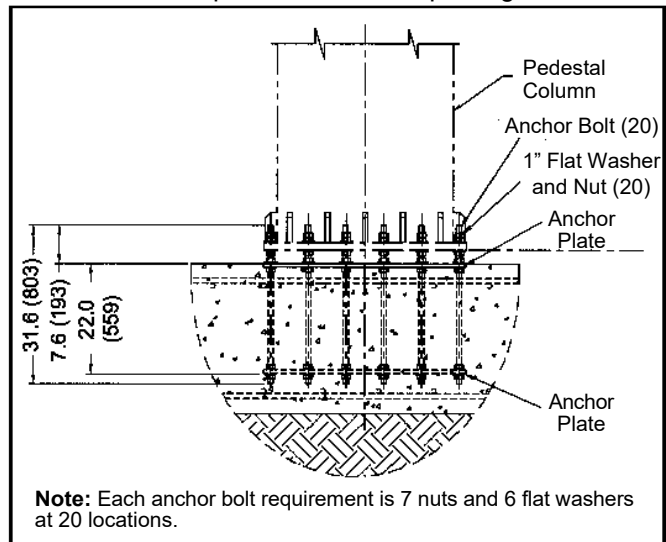

Note: Each anchor bolt requirement is 7 nuts and 6 flat washers at 20 locations.

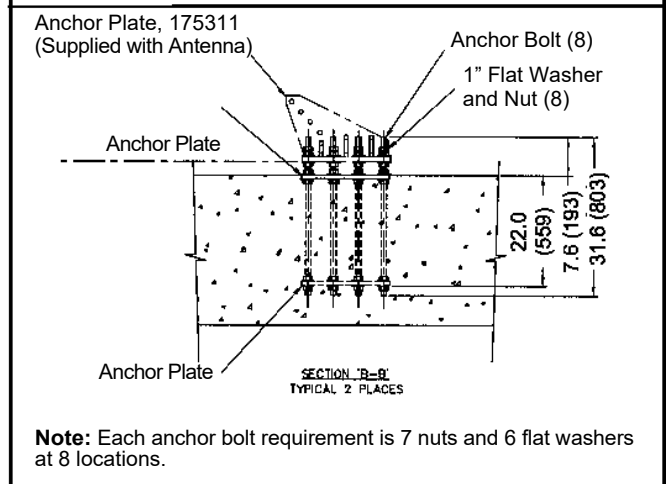

Note: Each anchor bolt requirement is 7 nuts and 6 flat washers at 8 locations.

Figure 2

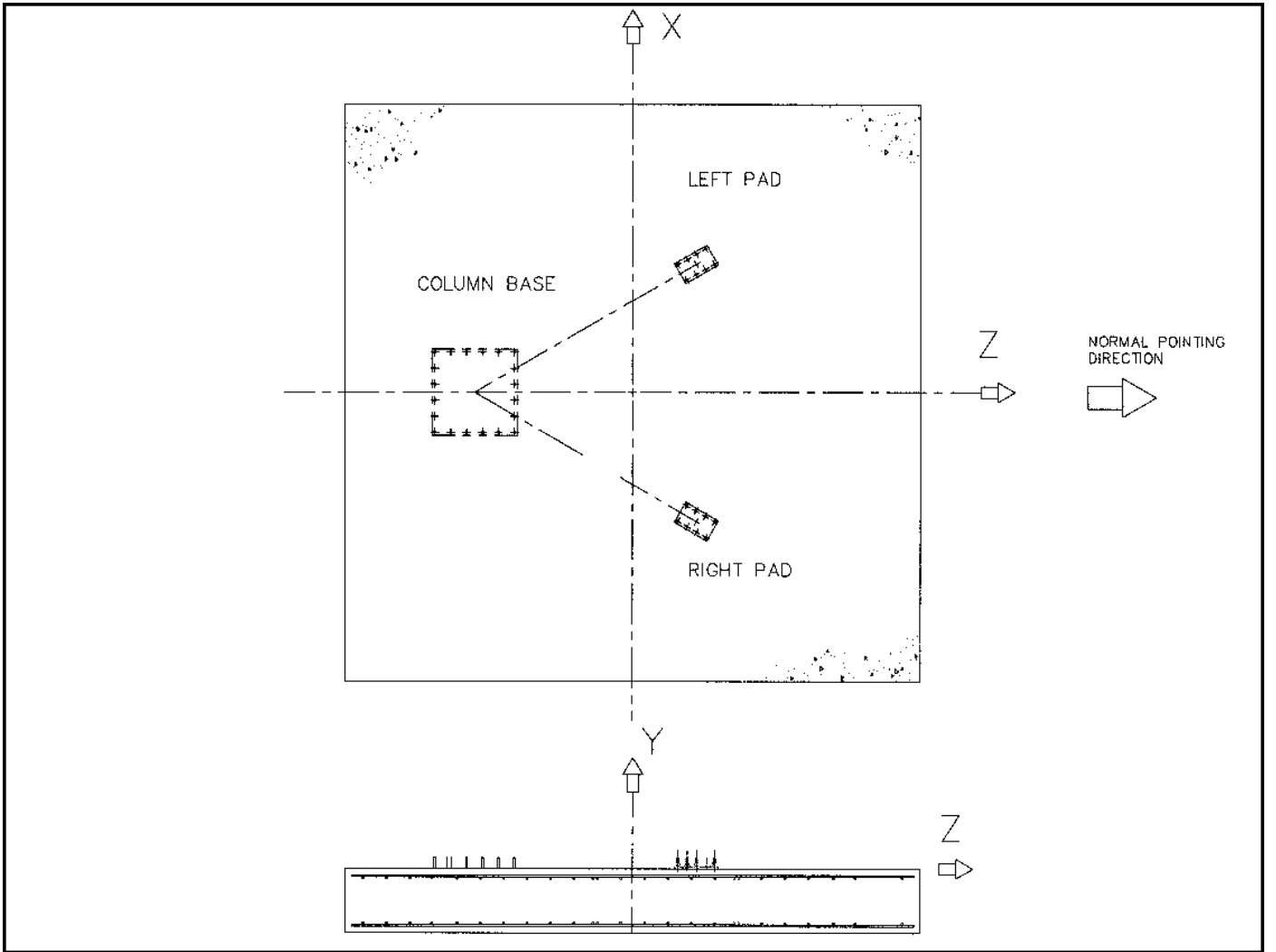

Figure 3a

9.4M Foundation Load Table

Wind = 125 mph

Antenna Azimuth = 0°

LOAD CASE	FOUNDATION	FOUNDATION LOAD					
		Force (1000 lbs)			Moment (1000 in.lbs)		
		Fx	Fy	Fz	Mx	My	Mz
El=0, Wind=15	Column Base	-0.5	-83.2	8.7	1364	-387	167
	Left Pad	15.3	31.0	-26.4			
	Right Pad	-16.2	32.9	-28.0			
El=0, Wind=135	Column Base	0.7	13.1	-2.8	-594	1825	-613
	Left Pad	-1.5	-6.6	2.6			
	Right Pad	10.1	-25.8	17.5			
El=15, Wind=15	Column Base	-0.4	-87.9	4.0	1335	0	60
	Left Pad	14.0	28.2	-24.2			
	Right Pad	-13.6	27.2	-23.5			
El=15, Wind=135	Column Base	-1.5	19.1	-5.7	-603	1651	-710
	Left Pad	-1.5	-7.6	2.5			
	Right Pad	11.9	-29.8	20.6			
El=45, Wind=45	Column Base	-0.2	-81.4	-2.3	979	-2	33
	Left Pad	8.2	15.1	-14.1			
	Right Pad	-7.9	14.5	-13.7			
El=45, Wind=135	Column Base	0.3	36.2	-14.6	-589	0	-49
	Left Pad	-9.8	-25.3	17			
	Right Pad	9.5	-24.5	16.4			
El=60, Wind=60	Column Base	-0.1	-71.4	-3.9	769	0	21
	Left Pad	5.6	9.3	-9.6			
	Right Pad	-5.4	8.9	-9.4			
El=60, Wind=120	Column Base	0.3	26.7	-13.2	-439	0	-39
	Left Pad	-8.0	-21.2	13.8			
	Right Pad	7.7	-20.5	13.3			
El=90, Wind=90	Column Base	7.8	-9.3	0.0	-34	-35	-916
	Left Pad	6.7	11.8	-11.7			
	Right Pad	6.7	-18.1	11.6			

Bold numbers are maximums

TABLE 1

9.4M Foundation Load Table							
Wind = 125 mph							
Antenna Azimuth = +60°							
LOAD CASE	FOUNDATION	FOUNDATION LOAD					
		Force (1000 lbs)			Moment (1000 in.lbs)		
		Fx	Fy	Fz	Mx	My	Mz
El=0, Wind=15	Column Base	5.6	-50.4	4.8	686	-374	-2937
	Left Pad	25.0	52.6	-43.3			
	Right Pad	8.3	-22.0	14.4			
El=0, Wind=135	Column Base	-2.4	12.0	-2.5	-587	-1	906
	Left Pad	-9.6	-24.6	16.6			
	Right Pad	1.5	-6.8	2.6			
El=15, Wind=15	Column Base	8.0	-57.3	2.1	640	8	-2715
	Left Pad	21.9	45.7	-38.0			
	Right Pad	8.0	-21.0	14.0			
El=15, Wind=135	Column Base	-1.4	19.0	-6.6	-577	1644	939
	Left Pad	-11.2	-28.3	19.5			
	Right Pad	2.1	-7.9	3.5			
El=45, Wind=45	Column Base	8.4	-63.2	-1.4	510	4	-1733
	Left Pad	12.8	25.3	-22.1			
	Right Pad	4.9	-13.9	8.5			
El=45, Wind=135	Column Base	5.0	14.8	-7.4	-265	-8	1556
	Left Pad	-15.5	-38.0	27.0			
	Right Pad	-5.8	9.6	-10.1			
El=60, Wind=60	Column Base	7.7	-58.8	-2.2	416	2	-1261
	Left Pad	8.7	16.3	-15.1			
	Right Pad	3.4	-10.7	5.9			
El=60, Wind=120	Column Base	5.3	9.3	-6.8	-195	36	1225
	Left Pad	-12.7	-31.5	22.0			
	Right Pad	-4.7	7.3	-8.3			
El=90, Wind=90	Column Base	-2.5	11.1	-9.0	-229	-38	-482
	Left Pad	-1.4	-6.3	2.3			
	Right Pad	7.8	-20.6	13.5			

Bold numbers are maximums

TABLE 1 (Con't)

9.4M Foundation Load Table

Wind = 125 mph

Antenna Azimuth = -60°

LOAD CASE	FOUNDATION	FOUNDATION LOAD					
		Force (1000 lbs)			Moment (1000 in.lbs)		
		Fx	Fy	Fz	Mx	My	Mz
El=0, Wind=15	Column Base	-5.9	-45.4	3.6	727	-394	3056
	Left Pad	-9.9	-25.3	17.3			
	Right Pad	-24.5	51.4	-42.5			
El=0, Wind=135	Column Base	2.1	-12.6	0.4	-92	1828	-1383
	Left Pad	8.7	16.3	-15.1			
	Right Pad	9.8	-23.0	15.4			
El=15, Wind=15	Column Base	-5.9	-45.4	3.6	727	-394	3056
	Left Pad	-9.9	-25.3	17.3			
	Right Pad	-24.5	51.4	-42.5			
El=15, Wind=135	Column Base	-0.9	-11.6	1.5	-113	1653	-1525
	Left Pad	10.4	20.1	-18.0			
	Right Pad	10.1	-25.7	17.5			
El=45, Wind=45	Column Base	-8.6	-62.7	-1.7	567	-4	1761
	Left Pad	-4.9	-14.0	8.5			
	Right Pad	-12.6	24.8	-21.8			
El=45, Wind=135	Column Base	-4.7	13.8	-6.8	-363	8	-1595
	Left Pad	5.8	9.8	-10.2			
	Right Pad	15.2	-37.2	26.4			
El=60, Wind=60	Column Base	-7.8	-58.5	-2.5	452	-2	1279
	Left Pad	-3.4	-10.7	5.9			
	Right Pad	-8.6	16.0	-14.9			
El=60, Wind=120	Column Base	-5.1	8.5	-6.2	-276	7	-1256
	Left Pad	4.8	7.4	-8.3			
	Right Pad	12.4	-30.9	21.5			
El=90, Wind=90	Column Base	-3.1	-30.1	9.2	184	-38	-437
	Left Pad	8.1	14.9	-14.0			
	Right Pad	-1.1	-0.6	-1.9			

Bold numbers are maximums

TABLE 1 (Con't)

General Notes - Pedestal Mount

1. Remove all burrs and sharp edges.
2. Dimensions apply before plating.
3. Interpret drawing per ANSI Y1 4.5M-1 982.
4. Dimensions are shown in feet and inches. Dimensions in brackets [] are in millimeters.
5. A tolerance of $\pm 1/8$ " [3] applies to all anchor bolt layout dimensions.
6. Level all shear caps individually and to within $\pm 1/4$ " [6] of each other.

7. Foundation Notes:

- A) This foundation is a typical design only. Certification of its suitability for a particular installation by a professional engineer is required prior to its use for actual fabrication.
- B) Contractor shall field verify all dimensions locating existing construction before fabrication of new construction begins.
- C) Concrete and related work shall be mixed, placed and cured in accordance with "Building Code Requirements for Reinforced Concrete" ACI 318-89 (Rev. 88) and "Specifications for Structural Concrete" ACI 301-84 (Rev. 88) publication SP-15 (88).
- D) Concrete for foundations shall develop a compressive strength of at least 3000 psi [211 kgf/cm²] in 28 days with a maximum slump of 3" [76] at time of placing.
- E) Reinforcing bars shall conform to ASTM A 615 [S1] grade 60 deformed type $F_y = 60000$ psi [4219 kgf/cm²].
- F) Unless otherwise noted, concrete cover of reinforcing bars shall conform to minimum requirements of ACI 318-89 (Rev. 88).
- G) Fabrication of reinforcing steel shall be in accordance with "Manual of Standard Practice for Detailing Reinforcing Concrete Structures" ACI 315-80 (Rev. 86).
- H) Provide $3/4$ " x 45° [19 x 45°] chamfer on all exposed concrete edges.
- J) Foundations have been designed to rest on undisturbed soil (per EIA-41 1-A and RS-222-D) with a minimum allowable net vertical bearing capacity of 2000 psf [9770 kgf/m²]. If undesirable soil conditions are encountered, the engineer shall be notified.
- K) Backfills shall be suitable excavated material or other suitable material compacted in 6" [152] lifts to 90% of maximum density as determined by ASTM D1557.
- L) If this foundation is to be located in an area where annual frost penetration depth exceeds 24" [610], the local building code specifying a minimum required foundation depth should be consulted.

8. Grounding Electrode System Notes:

- The grounding system shown represents the minimum requirements to achieve satisfactory grounding. Actual site conditions and soil resistivity levels will determine final grounding system design to comply with the following:
- A) All ground ring, ground rod and antenna structure connections to be ERICO® products, Inc. Calweld® exothermic type welded electrical connections or equivalent.
 - B) Ground rods shall be driven to a depth below permanent moisture level (minimum depth shown) as dictated by geographical location.
 - C) The antenna structure shall be connected to a grounding electrode system consisting of a number of interconnected ground rods. The system shall meet the requirements of the Underwriters' Laboratories Publication No. UL96A for Lightning protection.
 - D) The grounding electrode system to earth resistance shall not exceed 10 Ohms, measured with a Biddle 3 terminal device or equivalent. The grounded conductor (neutral) supplied to all ac equipment on the antenna structure should be disconnected before taking measurement.
 - E) Actual site conditions may require longer ground rods, additional ground rods and/or land fill additives to reduce soil resistivity levels.
 - F) Avoid sharp bends when routing grounding wire. Grounding wires to antenna structure to be run as short and straight as possible.
 - G) Final grade directly above grounding electrode system to be water permeable.

9. Power/IFL Conduit Notes:

- A) Electrical power - Figure 1 depicts suggested location for electrical power conduit to antenna. Size, type and depth to bury conduit to be determined by customer in compliance with local codes. Direction to route conduit to be determined by the relative location of communications building/ shelter. Power conduit to extend 6" (min.) above surface of foundation slab. Open ends of conduit to be sealed to prevent moisture and foreign particle contamination. Customer to provide main load center assembly and overcurrent protection devices for electrical equipment. Mounting location of load center to be determined by customer in accordance with local codes.
- B) IFL cable - Figure 1 depicts suggested location for IFL conduit. Conduit required only if no other means for routing IFL cables is provided. Size, type and depth to bury conduit to be determined by customer in compliance with local codes. Direction to route conduit to be determined by the relative location of communications building/shelter. IFL conduit to extend 36" (minimum) above surface of foundation slab. All bends to be large radius with a maximum of (2) 90° bends per run. Open ends of conduit to be sealed to prevent moisture and foreign particle contamination.

**9.4-Meter
Earth Station Antenna
(Pedestal Mount)**

- A = Lower Rim Height**
- B = Vertex Center Height**
- C = Subreflector Strut Tip Height**
- D = Upper Rim Height**
- E = Rim Extension**
- EI = Elevation Angle**

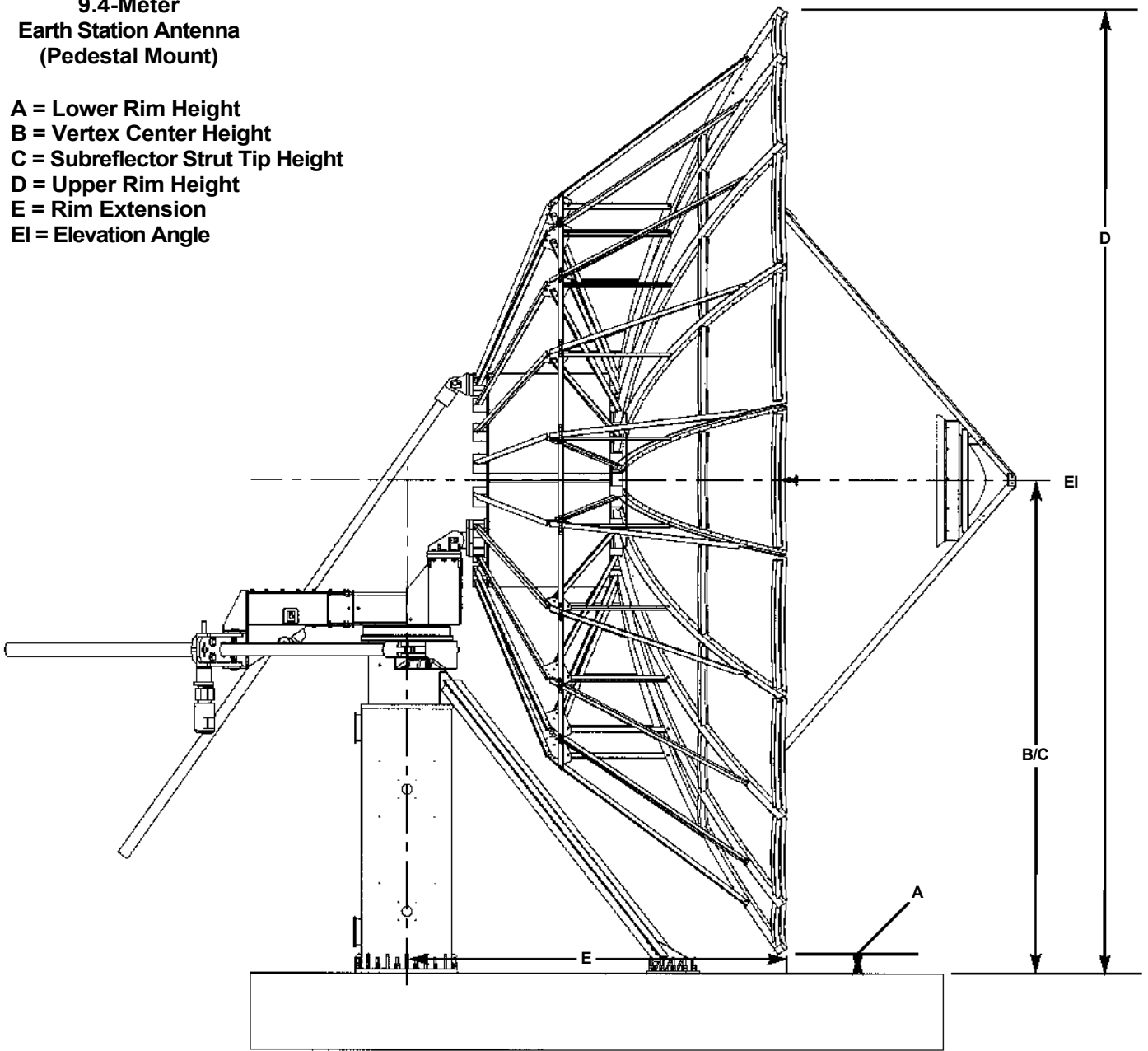

Side
View

Figure 4

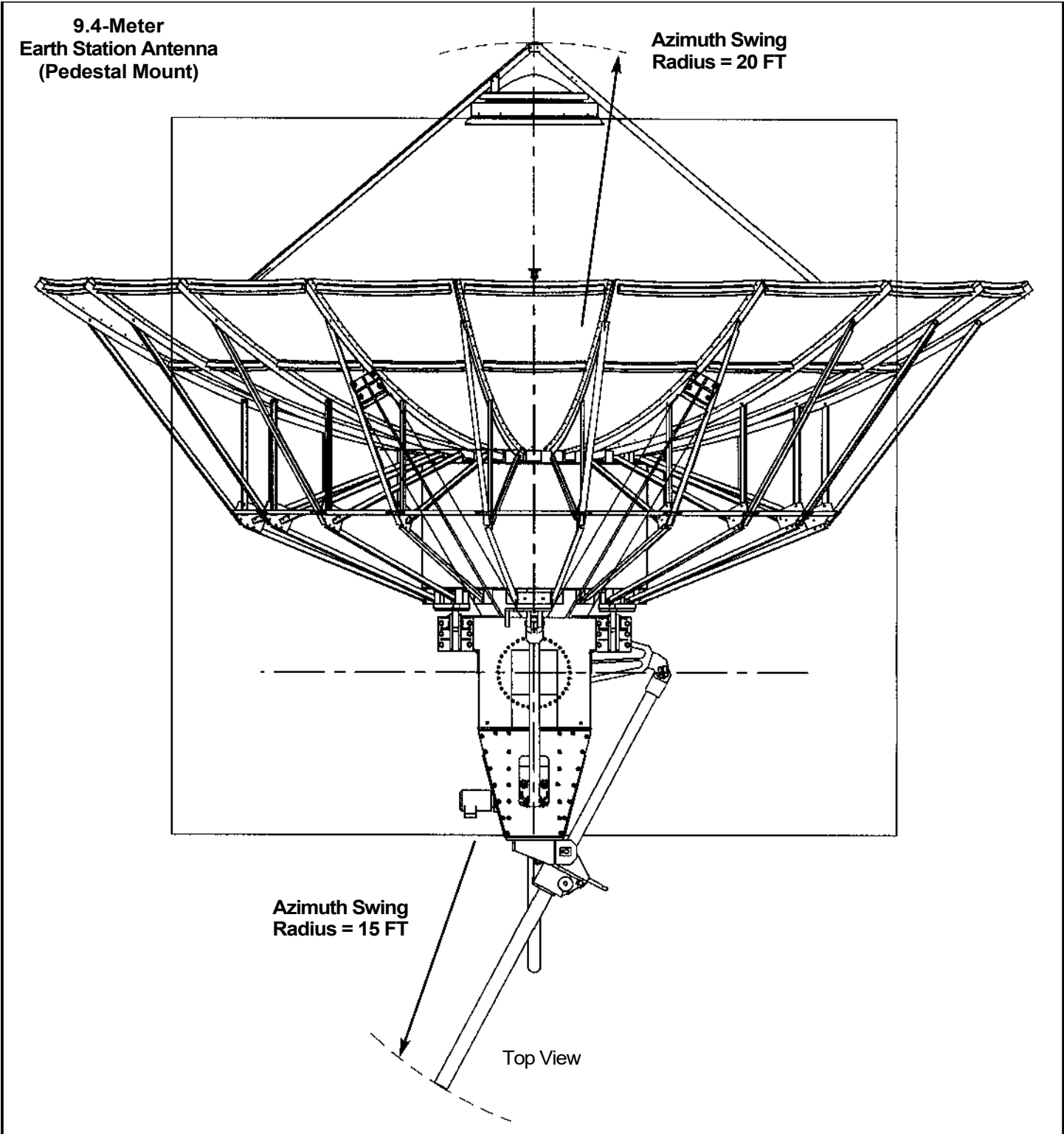

Figure 5

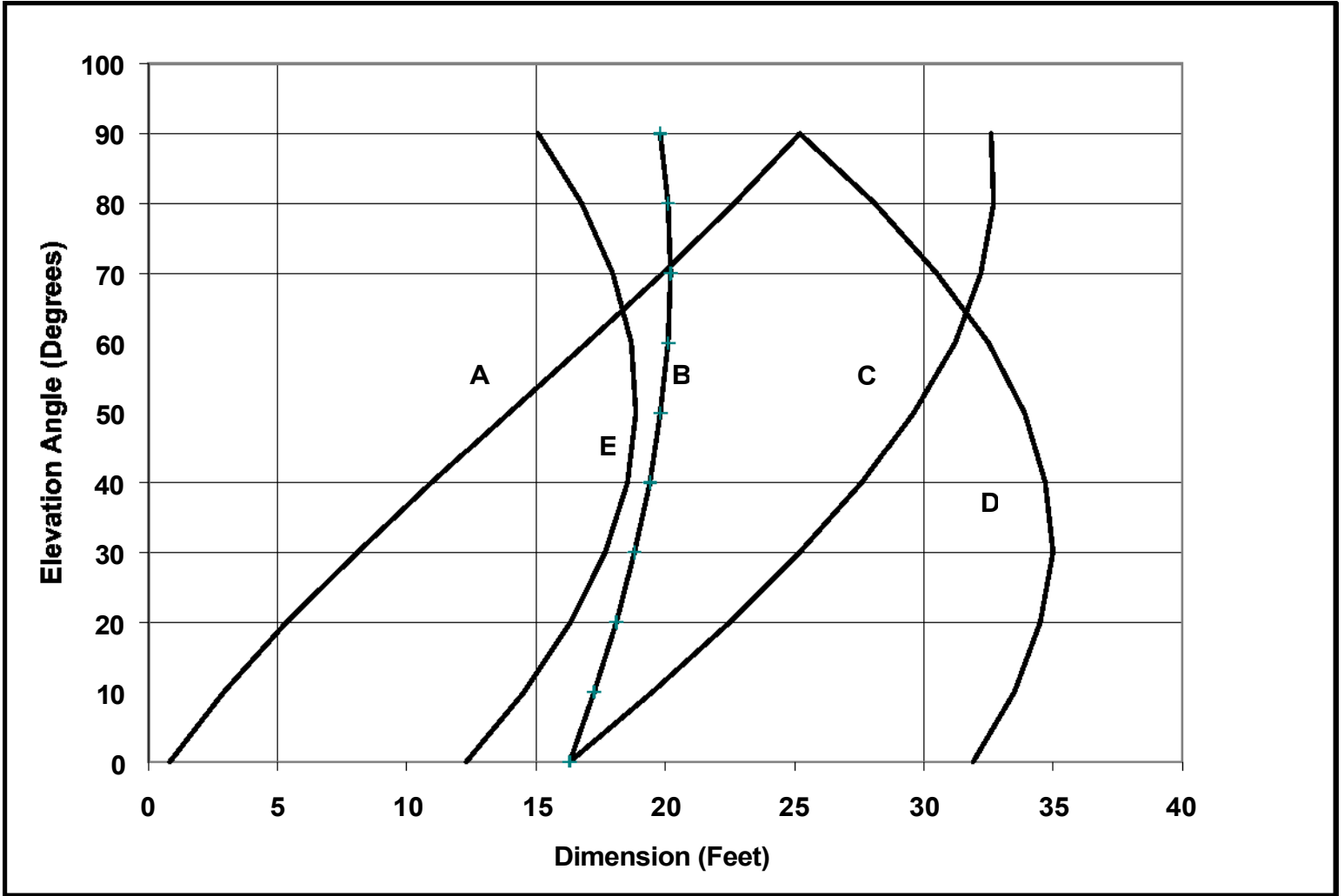

Figure 6