

Foundation Specifications



for 3.6-/3.7-Meter Earth Station Antennas

Introduction

This document specifies typical foundation characteristics, designs, requirements, and dimensional specifications for the Kratos 3.6-/3.7-Meter Earth Station Antennas.

Foundation Loading Characteristics

Foundation loads are applied to the foundation pad as shown in Figures 1 (pedestal mount) and 1A (pipe and flanged pipe mounts). Positive applied forces are in the direction of the X, Y and Z coordinate axes.

Varying load conditions are dependent upon incident angle of the wind and elevation/azimuth angles of the antenna. Foundation loading forces for various elevation/azimuth vs. wind conditions are listed in Tables 1 (pedestal mount) and 1A (pipe and flanged pipe mounts).

Foundation loading moment for various elevation/azimuth vs. wind conditions are listed in Tables 2 (pedestal mount) and 2A (pipe and flanged pipe mounts).

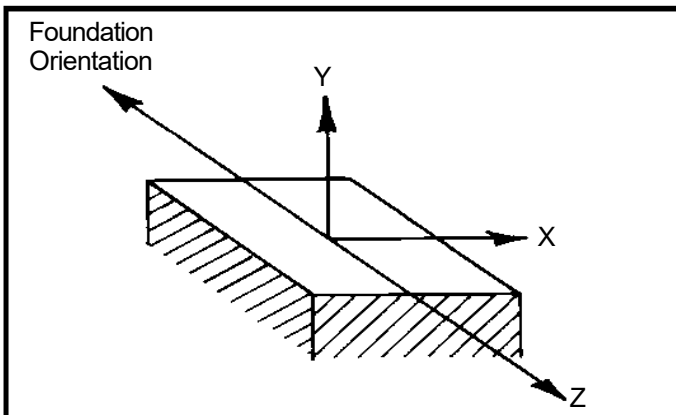

Figure 1

Foundation Designs

The selected foundation for a particular site is dependent upon local conditions. Soil borings and foundation analysis should be performed by a qualified civil engineer.

A typical slab type foundation design for a pedestal mount is shown in Figure 3. A copy of this design on a D-size (22" x 33") sheet is available from Kratos on request. Refer to Drawing 203340.

A typical embedded pipe foundation design is shown in Figure 3A. A copy of this design on a D-size (22" x 33") sheet is available from Kratos on request. Refer to Drawing 240165.

A typical flanged pipe foundation design is shown in Figure 3B. A copy of this design on a B-size (11" x 17") sheet is available from Kratos on request. Refer to Drawing 240165.

Figure 1A

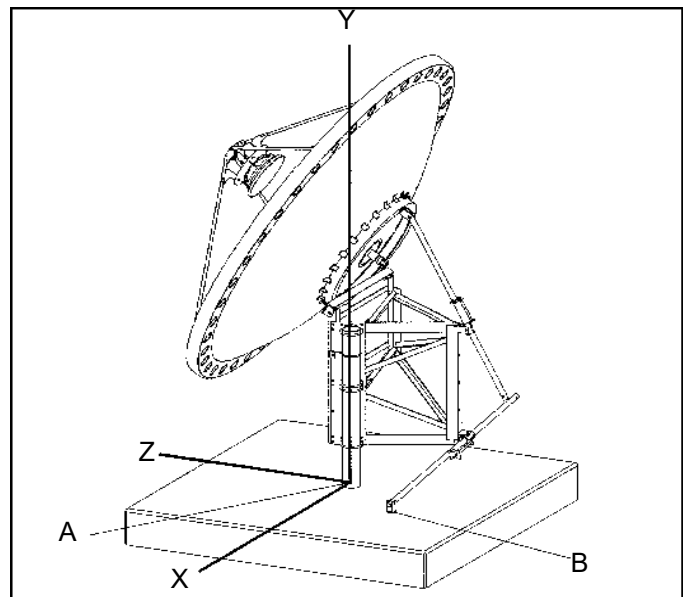

Anchor Bolt Requirements - Pedestal Mount

A typical anchor bolt installation configuration and corresponding dimensions are shown in Figure 2.

Kratos Type 203314 Anchor Bolt Kit includes anchor bolts, alignment plates and required mounting hardware as shown in Figure 2.

Anchor Bolt Requirements - Flanged Pipe Mount

A typical anchor bolt installation configuration and corresponding dimensions are shown in Figure 2B.

Kratos Type ANC36 Anchor Bolt Kit includes anchor bolts, alignment plates, azimuth strut anchor and required mounting hardware as shown in Figure 2B.

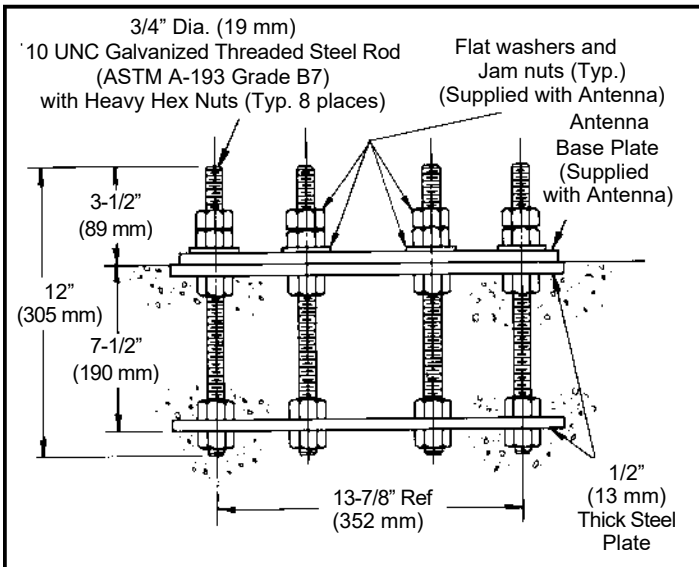

Figure 2

Pipe Mount Requirements

A typical embedded pipe mount installation configuration and corresponding dimensions are shown in Figure 2A.

Mounting pipe and required mounting hardware are customer supplied as shown in Figure 2A.

Foundation Orientation

Proper foundation orientation is required to obtain the desired orbital arc coverage from a particular site location. The required azimuth and elevation angles of the antenna, relative to the mount, must be determined to establish the appropriate foundation orientation. A specific foundation orientation requirement may be requested with the antenna as part of the installation package.

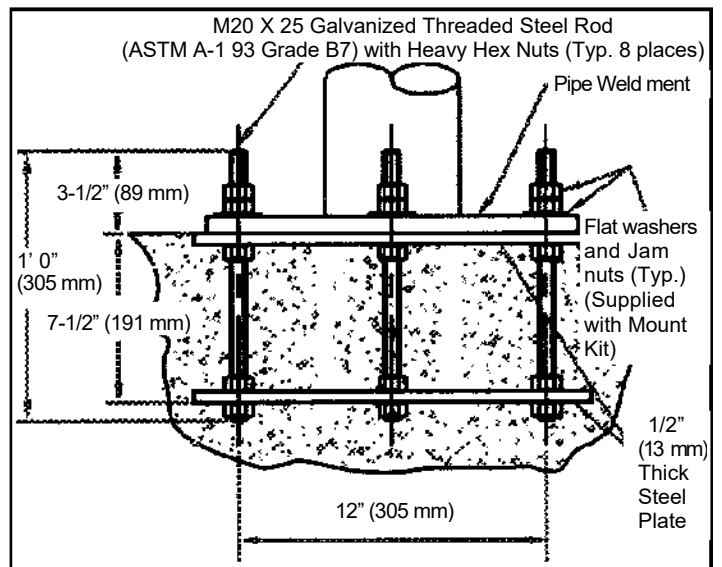

Figure 2B

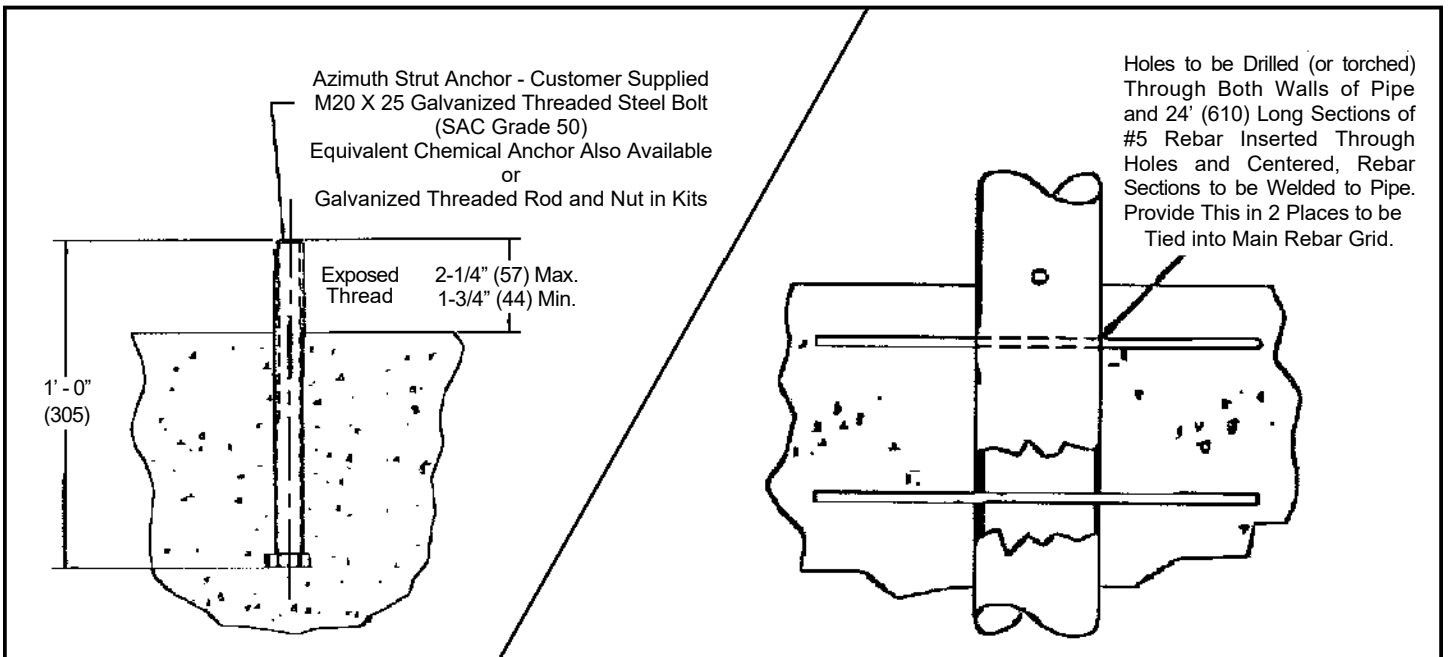

Figure 2A

FOUNDATION LOADING FORCES (lbs)										
EL = 0° Wind		AZ = 0°			AZ = +60°			AZ = -60°		
Speed (mph)	Angle (α)	X	y	z	X	y	z	X	y	z
125	0°	0	-1355	6682	-5730	-1355	3439	5843	-1355	3243
125	15°	216	-1355	6844	-5819	-1355	3609	6035	-1355	3235
125	-15°	-216	-1355	6844	-6035	-1355	3235	5819	-1355	3609
125	30°	323	-1355	6837	-5760	-1355	3698	6083	-1355	3139
125	-30°	-323	-1355	6837	-6083	-1355	3139	5760	-1355	3698
125	60°	-431	-1355	6116	-5512	-1355	2685	5081	-1355	3431
125	-60°	431	-1355	6116	-5081	-1355	3431	5512	-1355	2685
125	135	-1391	-1355	-2600	1556	-1355	-2505	-2947	-1355	-95
125	-135°	1391	-1355	-2600	2947	-1355	-95	-1556	-1355	-2505
125	180°	0	-1355	-4155	-3619	-1355	2042	3578	-1355	2113

FOUNDATION LOADING FORCES (lbs)										
EL = 30° Wind		AZ = 0°			AZ = +60°			AZ = -60°		
Speed (mph)	Angle (α)	X	y	z	X	y	z	X	y	z
125	30°	0	-5053	5760	-4988	-5053	2880	4988	-5053	2880
125	60°	-406	-4289	5368	-4852	-4289	2332	4446	-4289	3036
125	-60°	406	-4289	5368	-4446	-4289	3036	4852	-4289	2332
125	135°	-1136	-751	-2653	1730	-750	-2310	-2866	-751	-343
125	-135°	1136	-751	-2653	2866	-750	-343	-1730	-751	-2310
125	150°	0	-520	-3454	2991	-520	-1728	-2992	-520	-1726

FOUNDATION LOADING FORCES (lbs)										
EL = 60° Wind		AZ = 0°			AZ = +60°			AZ = -60°		
Speed (mph)	Angle (α)	X	y	z	X	y	z	X	y	z
125	+/-60°	0	-6436	3431	-2972	-6436	1716	2972	-6436	1716
125	120°	-4	-704	-2084	1803	-704	-1045	-1807	-704	-1039
125	-120°	4	-704	-2084	1807	-704	-1038	-1803	-704	-1045

FOUNDATION LOADING FORCES (lbs)											
EL = 90° Wind		AZ = 0°			AZ = +60°			AZ = -60°			
Speed (mph)	Angle (α)	X	y	z	X	y	z	X	y	z	
125	90°	Side Wind	-1172	-821	-3.0	-583	-821	-1016	-589	-821	1014
		Frontal Wind	0	-821	1172	-1015	-821	586	1015	-821	586
125	-90°	Side Wind	1172	-821	-3.0	589	-821	1014	583	-821	-1016
		Frontal Wind	0	-821	-1172	1015	-821	-586	-1015	-821	-586

Table 1. Foundation Loading Forces Table for 3.6-/3.7-Meter Pedestal Mount Earth Station Antennas

FOUNDATION LOADING FORCES (lbs)											
EL = 0° Wind		Location	AZ = 0°			AZ = -60°			AZ = +60°		
Speed (mph)	Angle (α)		X	y	z	X	y	z	X	y	z
			125	0°	A	-5784	1183	-8686	-8658	11588	-13395
		B	5783	-2115	1655	8657	-12515	6364	8949	-2545	6844
125	30°	A	-6514	1374	-8459	-9678	12826	-13643	-10000	1843	-14170
		B	6365	-2327	1822	9528	-13775	7005	9850	-2801	7533
125	60°	A	-7245	1565	-8233	-10698	14065	-13890	-11050	2077	-14466
		B	6947	-2540	1988	10400	-15035	7646	10751	-3057	8222
125	90°	A	4195	-2293	1760	5995	-8808	4711	6179	-2563	5011
		B	-3623	1318	-1037	-5424	7838	-3988	-5607	1584	-4288
125	120°	A	6019	-2911	3574	8658	-12463	7899	8927	-3307	8340
		B	-5311	1934	-1520	-7951	11491	-5845	-8220	2325	-6286
125	150°	A	4928	-2628	4666	7201	-10853	8391	7433	-2969	8770
		B	-4574	1665	-1309	-6847	9895	-5034	-7078	2001	-5413
125	180°	A	3838	-2345	5758	5745	-9244	8883	5939	-2631	9200
		B	-3836	1396	-1098	-5743	8300	-4222	-5937	1677	-4540

FOUNDATION LOADING FORCES (lbs)											
EL = 10° Wind		Location	AZ = 0°			AZ = -60°			AZ = +60°		
Speed (mph)	Angle (α)		X	y	z	X	y	z	X	y	z
			125	0°	A	-5799	-114	-8436	-8717	11668	-13488
		B	6271	-2107	1649	8716	-12601	6408	9011	-2563	6891
125	30°	A	-6428	144	-8310	-9901	13121	-13957	-10230	1885	-14496
		B	62711	-2293	1795	9748	-14092	7166	10077	-2865	7706
125	60°	A	-6911	357	-7928	-10790	14186	-14009	-11145	2094	-14590
		B	6628	-2424	1897	10489	-15164	7711	10843	-3083	8292
125	90°	A	4081	-2125	1716	5569	-8182	4376	5740	-2381	4655
		B	-3510	1276	-1005	-5038	7281	-3704	-5209	1471	-3983
125	120°	A	5826	-2558	3480	8150	-11731	7435	8403	-3113	7850
		B	-5124	1865	-1467	-7484	10816	-5502	-7737	2188	-5917
125	150°	A	4816	-2119	4536	6806	-10257	7930	7025	-2806	8288
		B	-4456	1622	-1275	-6471	9352	-4757	-6690	1891	-5116
125	180°	A	3567	-1647	5196	5070	-8157	7839	5241	-2322	8119
		B	-3543	1288	-1014	-5068	7325	-3726	-5240	1480	-4007

Note: Maximum values are **highlighted**. Azimuth angle follows the right-hand rule. Negative azimuth angle indicates clockwise rotation. Positive azimuth angle indicates counterclockwise rotation.

Table 1A. Foundation Loading Forces Table for 3.6-/3.7-Meter Pipe and Flanged Pipe Mount Earth Station Antennas

FOUNDATION LOADING FORCES (lbs)											
EL = 20° Wind		Location	AZ = 0°			AZ = -60°			AZ = +60°		
Speed (mph)	Angle (α)		X	y	z	X	y	z	X	y	z
			125	0°	A	-5367	-1429	-7856	-8759	11723	-13551
		B	5338	-1953	1528	8757	-12661	6439	9054	-2575	6923
125	30°	A	-6101	-1119	-7846	-10061	13334	-14183	-10396	1915	-14731
		B	5938	-2172	1700	9906	-14321	7283	10241	-2912	7831
125	60°	A	-6030	-878	-7081	-10484	13784	-13612	-10829	2035	-14177
		B	5793	-2119	1658	10192	-14734	7493	10536	-2995	8057
125	90°	A	3865	-1923	1622	5122	-7525	4025	5279	-2190	4281
		B	-3293	1197	-943	-4634	6697	-3407	-4791	1353	-3664
125	120°	A	5414	-2151	3249	7489	-10780	6832	7721	-2860	7213
		B	-4729	1721	-1354	-6877	9939	-5056	-7110	2011	-5437
125	150°	A	4525	-1613	41491	6205	-9351	7230	6404	-2558	7556
		B	-4158	1513	-1190	-5899	8526	-4337	-6099	1724	-4664
125	180°	A	3094	-1017	4523	4402	-7084	6807	4551	-2016	7051
		B	-3074	1117	-880	-4401	6361	-3236	-4550	1285	-3479

FOUNDATION LOADING FORCES (lbs)											
EL = 30° Wind		Location	AZ = 0°			AZ = -60°			AZ = +60°		
Speed (mph)	Angle (α)		X	y	z	X	y	z	X	y	z
			125	0°	A	-4780	-2680	-7038	-8782	11754	-13587
		B	4758	-1741	1362	8781	-12695	6456	9078	-2582	6942
125	30°	A	-5555	-2355	-7103	-10168	13475	-14334	-10506	1936	-14887
		B	-5390	-1972	1543	10010	-14472	7360	10349	-2943	7914
125	60°	A	-4762	-1952	-5829	-9801	12886	-12726	-10124	1903	-13253
		B	4595	-1682	1315	9528	-13775	7005	9850	-2800	7532
125	90°	A	3553	-1694	1479	4666	-6854	3666	4809	-1995	3900
		B	-2981	1083	-853	-4221	6100	-3103	-4364	1232	-3337
125	120°	A	4829	-1724	2902	6702	-9647	6114	6910	-2560	6455
		B	-4168	1517	-1193	-6154	8895	-4524	-6362	1799	-4865
125	150°	A	4103	-1169	3704	5478	-8256	6383	5654	-2258	6672
		B	-3728	1356	-1067	-5209	7528	-3829	-5385	1522	-4118
125	180°	A	2604	-542	3825	3756	-6044	5808	3883	-1720	6016
		B	-2590	941	-741	-3755	5427	-2761	-3882	1097	-2969

Table 1A. (continued)

FOUNDATION LOADING FORCES (lbs)											
EL = 45° Wind		Location	AZ = 0°			AZ = -60°			AZ = +60°		
Speed (mph)	Angle (α)		X	y	z	X	y	z	X	y	z
125	0°	A	-3678	-4345	-5466	-8790	11765	-13600	-9087	1633	-14088
		B	3661	-1343	1049	8789	-12707	6462	9086	-2584	6948
125	30°	A	-4392	-4056	-5576	-10252	13587	-14452	-10593	1952	-15010
		B	4229	-1548	1210	10093	-14592	7421	10435	-2967	7979
125	60°	A	-2574	-2938	-3623	-8175	10748	-10614	-8444	1587	-11054
		B	2553	-936	731	7947	-11489	5842	8215	-2336	6282
125	90°	A	2895	-1313	1168	3974	-5838	3122	4096	-1699	3321
		B	-2329	845	-666	-3595	5195	-2643	-3717	1050	-2842
125	120°	A	3737	-1126	2229	5343	-7691	4875	5509	-2041	5146
		B	-3122	1135	-894	-4906	7091	-3607	-5072	1435	-3879
125	150°	A	3340	-685	2872	4312	-6499	5025	4451	-1778	5252
		B	-2947	1071	-843	-4100	5925	-3014	-4239	1198	-3241
125	180°	A	1914	-122	2836	2851	-4587	4408	2947	-1306	4566
		B	-1906	691	-545	-2850	4119	-2095	-2946	832	-2253

FOUNDATION LOADING FORCES (lbs)											
EL = 60° Wind		Location	AZ = 0°			AZ = -60°			AZ = +60°		
Speed (mph)	Angle (α)		X	y	z	X	y	z	X	y	z
125	0°	A	-2369	-5660	-3560	-8711	11660	-13478	-9006	1618	-13961
		B	2369	-869	678	8710	-12593	6404	9005	-2561	6886
125	30°	A	-2413	-4731	-3173	-8832	11705	-12450	-9126	1681	-12931
		B	2321	-852	664	8695	-12571	6393	8989	-2556	6874
125	60°	A	-744	-2904	-1640	-5949	7822	-7724	-6145	1155	-8045
		B	882	-326	252	5784	-8361	4252	5979	-1700	4572
125	90°	A	2125	-917	800	3375	-4959	2652	3479	-1443	2821
		B	-1559	564	-446	-3054	4413	-2245	-3157	892	-2414
125	120°	A	2573	-661	1499	3952	-5689	3605	4075	-1509	3806
		B	-2005	727	-574	-3629	5245	-2668	-3752	1061	-2869
125	150°	A	2378	-369	1996	3112	-4691	3627	3212	-1283	3790
		B	-1996	724	-571	-2959	4277	-2176	-3059	865	-2339
125	180°	A	1349	-33	2023	2053	-3303	3174	2122	-940	3288
		B	-13481	487	-386	-2052	2966	-1509	-21221	599	-1622

Table 1A. (continued)

FOUNDATION LOADING FORCES (lbs)											
EL = 75° Wind		Location	AZ = 0°			AZ = -60°			AZ = +60°		
Speed (mph)	Angle (α)		X	y	z	X	y	z	X	y	z
125	0°		A	-705	-3345	-1057	-4524	6055	-6999	-4677	840
		B	704	-261	201	4523	-6539	3326	4676	-1330	3576
125	30°	A	-442	-2939	-916	-4666	6184	-6578	-4822	888	-6832
		B	543	-203	155	4594	-6642	3378	4750	-1351	3632
125	60°	A	237	-1873	-452	-3342	4394	-4339	-3452	649	-4519
		B	72	-31	21	3249	-4697	2388	3358	-955	2568
125	90°	A	1258	-528	380	2939	-4318	2309	3029	-1256	2456
		B	-692	248	-198	-2659	3842	-1955	-2749	776	-2102
125	120°	A	1477	-376	824	2776	-3996	2533	2863	-1060	2674
		B	-950	342	-272	-2549	3685	-1874	-2636	745	-2016
125	150°	A	1327	-221	1141	1895	-2856	2208	1956	-781	2308
		B	-1004	362	-287	-1802	2604	-1325	-1863	527	-1425
125	180°	A	802	-85	1202	1200	-1931	1855	1241	-550	1922
		B	-800	288	-229	-1200	1734	-882	-1240	350	-948

FOUNDATION LOADING FORCES (lbs)											
EL = 90° Wind		Location	AZ = 0°			AZ = -60°			AZ = +60°		
Speed (mph)	Angle (α)		X	y	z	X	y	z	X	y	z
125	0°		A	-470	-76	-704	-760	1017	-1176	-786	141
		B	467	-175	134	760	-1098	559	785	-223	601
125	30°	A	-229	-62	-639	-897	1188	-1264	-927	171	-1313
		B	510	-191	146	883	-1276	649	913	-260	698
125	60°	A	72	-97	-405	-1050	1381	-1364	-1085	204	-1420
		B	418	-157	120	1021	-1476	751	1056	-300	807
125	90°	A	353	-171	-63	2774	-4076	2180	2859	-1186	2319
		B	214	-83	61	-2510	3627	-1845	-2595	733	-1984
125	120°	A	540	-266	295	2258	-3250	2060	2328	-862	-2175
		B	-47	13	-14	-2073	2997	-1524	-2143	606	-1639
125	150°	A	581	-356	575	1273	-1919	1484	1314	-525	1551
		B	-296	103	-85	-1211	1750	-890	-1252	354	-957
125	180°	A	467	-418	700	750	-1206	1159	775	-343	1201
		B	-465	165	-133	-749	1083	-551	-775	219	-592

Table 1A. Foundation Loading Forces Table for 3.6-/3.7-Meter Pipe and Flanged Pipe Mount Earth Station Antennas

FOUNDATION LOADING FORCES (in-lbs)										
EL = 0°		AZ = 0°			AZ = +60°			AZ = -60°		
Wind Speed (mph)	Angle (α)	X	y	z	X	y	z	X	y	z
125	0°	508145	0	-9062	261925	-5296	435517	246220	-5281	-444571
125	15°	521125	-24396	-17307	275546	-24397	442648	245579	-24391	-459955
125	-15°	521125	24396	17307	245579	24391	459955	275546	24397	-442648
125	30°	520564	-35277	-25880	282677	-35260	437920	237867	-35277	-463800
125	-30°	520564	35277	25880	237887	35277	463801	282677	35260	-437920
125	60°	462794	-40320	34534	201510	-40333	418049	261284	-40326	-383515
125	-60°	462794	40320	-34534	261284	40326	383515	201510	40333	-418049
125	135	-235576	119340	111454	-214338	119357	-148274	-21237	119349	259728
125	-135°	-235576	-119340	-111454	-21237	-119349	-259728	-214338	-119357	148274
125	180°	305669	-1831	3285	149990	-1828	266373	155679	-1834	-263088

FOUNDATION LOADING FORCES (in-lbs)										
EL = 30°		AZ = 0°			AZ = +60°			AZ = -60°		
Wind Speed (mph)	Angle (α)	X	y	z	X	y	z	X	y	z
125	30°	369312	0	0	184653	-8	319808	184653	8	-319808
125	60°	359158	-35338	9393	171412	-35327	315753	187749	-35327	-306360
125	-60°	359158	35338	-9393	187749	35327	306360	171412	35327	-315753
125	135°	-278406	77672	128208	-250197	77659	-177029	-28202	77669	305250
125	-135°	-278406	-77672	-128208	-28194	-77669	-305237	-250205	-77669	177042
125	150°	-363789	77	118	-182006	78	-315014	-181784	82	315135

FOUNDATION LOADING FORCES (in-lbs)										
EL = 60°		AZ = 0°			AZ = +60°			AZ = -60°		
Wind Speed (mph)	Angle (α)	X	y	z	X	y	z	X	y	z
125	+/-60°	179372	0	0	89728	-2	155403	89728	2	-155403
125	120°	-253990	137	510	-127395	129	-219723	-126596	132	220232
125	-120°	-253990	137	-510	-126501	-145	-220232	-127395	-129	219723

FOUNDATION LOADING FORCES (in-lbs)											
EL = 90°		AZ = 0°			AZ = +60°			AZ = -60°			
Wind Speed (mph)	Angle (α)	X	y	z	X	y	z	X	y	z	
125	90°	Side Wind	-399	-147	157683	-136713	-145	78458	136405	-146	79225
		Frontal Wind	157686	0	0	78848	4	136566	78848	1	-136566
125	-90°	Side Wind	-399	-147	-157683	136405	146	-79225	-136713	145	-78458
		Frontal Wind	-157686	0	0	-78845	1	-136561	-78845	-1	136561

Table 2. Foundation Loading Moment Table for 3.6-/3.7-Meter Pedestal Mount Earth Station Antennas

FOUNDATION LOADING FORCES (in-lbs)											
EL = 0° Wind		Location	AZ = 0°			AZ = -60°			AZ = +60°		
Speed (mph)	Angle (α)		X	y	z	X	y	z	X	y	z
125	0°	A	-505040	14140	49725	-230710	0	-117720	-560750	0	83726
		B	0	0	0	0	0	0	0	0	0
125	30°	A	-466350	0	65517	-164420	0	-118780	-527660	0	102940
		B	0	0	0	0	0	0	0	0	0
125	60°	A	-427680	0	81308	-98134	0	-119840	-494590	0	122150
		B	0	0	0	0	0	0	0	0	0
125	90°	A	37153	0	-52582	-134590	0	52245	71936	0	-73812
		B	0	0	0	0	0	0	0	0	0
125	120°	A	128940	0	-73649	-122850	0	80039	179970	0	-104790
		B	0	0	0	0	0	0	0	0	0
125	150°	A	235820	0	-41570	18999	0	90775	279750	0	-68381
		B	0	0	0	0	0	0	0	0	0
125	180°	A	342700	0	-9492	160840	0	101510	379530	0	-31974
		B	0	0	0	0	0	0	0	0	0

FOUNDATION LOADING FORCES (in-lbs)											
EL = 10° Wind		Location	AZ = 0°			AZ = -60°			AZ = +60°		
Speed (mph)	Angle (α)		X	y	z	X	y	z	X	y	z
125	0°	A	-467530	0	81582	-215759	0	-110091	-524410	0	78300
		B	0	0	0	0	0	0	0	0	0
125	30°	A	-445540	0	95985	-159124	0	-114954	-510665	0	99625
		B	0	0	0	0	0	0	0	0	0
125	60°	A	-404960	0	109750	-94579	0	-115498	-434184	0	107231
		B	0	0	0	0	0	0	0	0	0
125	90°	A	35318	0	-67976	-160136	0	62161	98626	0	-101198
		B	0	0	0	0	0	0	0	0	0
125	120°	A	133760	0	-94073	-135290	0	88144	210274	0	-122435
		B	0	0	0	0	0	0	0	0	0
125	150°	A	239680	0	-59607	19596	0	93628	288541	0	-70530
		B	0	0	0	0	0	0	0	0	0
125	180°	A	321850	0	-22914	151379	0	95539	357204	0	-300903
		B	0	0	0	0	0	0	0	0	0

Note: Maximum values are **highlighted**. Azimuth angle follows the right-hand rule. Negative azimuth angle indicates clockwise rotation. Positive azimuth angle indicates counterclockwise rotation.

Table 2A. Foundation Loading Moment Table for 3.6-/3.7-Meter Pipe and Flanged Pipe Mount Earth Station Antennas

FOUNDATION LOADING FORCES (in-lbs)											
EL = 20° Wind		Location	AZ = 0°			AZ = -60°			AZ = +60°		
Speed (mph)	Angle (α)		X	y	z	X	y	z	X	y	z
125	0°	A	-426440	0	104390	-199591	0	-101842	-485114	0	72433
		B	0	0	0	0	0	0	0	0	0
125	30°	A	-410910	0	123720	-149827	0	-108237	-480826	0	93803
		B	0	0	0	0	0	0	0	0	0
125	60°	A	-360610	0	126550	-86149	0	-105204	-434184	0	107231
		B	0	0	0	0	0	0	0	0	0
125	90°	A	32763	0	-81966	-1845207	0	71629	98626	0	-101198
		B	0	0	0	0	0	0	0	0	0
125	120°	A	133820	0	-110420	-143536	0	93516	210274	0	-122435
		B	0	0	0	0	0	0	0	0	0
125	150°	A	233320	0	-74999	19445	0	92906	286318	0	-69986
		B	0	0	0	0	0	0	0	0	0
125	180°	A	295920	0	-30021	139544	0	88070	329278	0	-27740
		B	0	0	0	0	0	0	0	0	0

FOUNDATION LOADING FORCES (in-lbs)											
EL = 30° Wind		Location	AZ = 0°			AZ = -60°			AZ = +60°		
Speed (mph)	Angle (α)		X	y	z	X	y	z	X	y	z
125	0°	A	-375460	0	123200	-179645	0	-91664	-436634	0	65194
		B	0	0	0	0	0	0	0	0	0
125	30°	A	-364820	0	147450	-137383	0	-99248	-440893	0	86013
		B	0	0	0	0	0	0	0	0	0
125	60°	A	-301450	0	128380	-86149	0	-105204	-434184	0	107231
		B	0	0	0	0	0	0	0	0	0
125	90°	A	29567	0	-94127	-184527	0	71629	98626	0	-101198
		B	0	0	0	0	0	0	0	0	0
125	120°	A	129230	0	-121860	-143536	0	93516	210274	0	-122435
		B	0	0	0	0	0	0	0	0	0
125	150°	A	220740	0	-86987	18825	0	89943	277186	0	-67754
		B	0	0	0	0	0	0	0	0	0
125	180°	A	269640	0	269640	127464	0	80446	300774	0	-25339
		B	0	0	0	0	0	0	0	0	0

Table 2A. (continued)

FOUNDATION LOADING FORCES (in-lbs)											
EL = 45° Wind		Location	AZ = 0°			AZ = -60°			AZ = +60°		
Speed (mph)	Angle (α)		X	y	z	X	y	z	X	y	z
125	0°		A	-286800	0	143060	-145705	0	-74346	-354142	0
		B	0	0	0	0	0	0	0	0	0
125	30°	A	-281830	0	172890	-115437	0	-83394	-370464	0	72273
		B	0	0	0	0	0	0	0	0	0
125	60°	A	-204160	0	100770	-86149	0	-105204	-434184	0	107231
		B	0	0	0	0	0	0	0	0	0
125	90°	A	23294	0	-106910	-184527	0	71629	98626	0	-101198
		B	0	0	0	0	0	0	0	0	0
125	120°	A	114580	0	-129000	-143536	0	93516	210274	0	-122435
		B	0	0	0	0	0	0	0	0	0
125	150°	A	198430	0	-98644	17582	0	84005	258886	0	-63281
		B	0	0	0	0	0	0	0	0	0
125	180°	A	234280	0	-32111	110941	0	700717	261783	0	-22054
		B	0	0	0	0	0	0	0	0	0

FOUNDATION LOADING FORCES (in-lbs)											
EL = 60° Wind		Location	AZ = 0°			AZ = -60°			AZ = +60°		
Speed (mph)	Angle (α)		X	y	z	X	y	z	X	y	z
125	0°		A	-184060	0	151710	-108437	0	-55330	-263561	0
		B	0	0	0	0	0	0	0	0	0
125	30°	A	-172730	0	150310	-79944	0	-57753	-256556	0	50051
		B	0	0	0	0	0	0	0	0	0
125	60°	A	-117360	0	46361	-86149	0	-105204	-434184	0	107231
		B	0	0	0	0	0	0	0	0	0
125	90°	A	16790	0	-114960	-184527	0	71629	98626	0	-101198
		B	0	0	0	0	0	0	0	0	0
125	120°	A	94748	0	-126000	-143536	0	93516	210274	0	-122435
		B	0	0	0	0	0	0	0	0	0
125	150°	A	169930	0	-97121	15529	0	74198	228662	0	-55893
		B	0	0	0	0	0	0	0	0	0
125	180°	A	208300	0	-25056	98429	0	62121	232260	0	-19567
		B	0	0	0	0	0	0	0	0	0

Table 2A. (continued)

FOUNDATION LOADING FORCES (in-lbs)											
EL = 75° Wind		Location	AZ = 0°			AZ = -60°			AZ = +60°		
Speed (mph)	Angle (α)		X	y	z	X	y	z	X	y	z
125	0°	A	-95687	0	77382	-55946	0	-28546	-135978	0	20303
		B	0	0	0	0	0	0	0	0	0
125	30°	A	-91063	0	47411	-35845	0	-25895	-115033	0	22442
		B	0	0	0	0	0	0	0	0	0
125	60°	A	-63040	0	-24074	-86149	0	-105204	-434184	0	107231
		B	0	0	0	0	0	0	0	0	0
125	90°	A	9922	0	-116640	-184527	0	71629	98626	0	-101198
		B	0	0	0	0	0	0	0	0	0
125	120°	A	74290	0	-115050	-143536	0	93516	210274	0	-122435
		B	0	0	0	0	0	0	0	0	0
125	150°	A	128200	0	-78998	11948	0	57085	175925	0	-43002
		B	0	0	0	0	0	0	0	0	0
125	180°	A	151240	0	-16230	71362	0	45038	168391	0	-14186
		B	0	0	0	0	0	0	0	0	0

FOUNDATION LOADING FORCES (in-lbs)											
EL = 90° Wind		Location	AZ = 0°			AZ = -60°			AZ = +60°		
Speed (mph)	Angle (α)		X	y	z	X	y	z	X	y	z
125	0°	A	-107270	0	2357	-48779	0	-24889	-118558	0	17702
		B	0	0	0	0	0	0	0	0	0
125	30°	A	-91762	0	-53530	-37091	0	-26795	-119032	0	23222
		B	0	0	0	0	0	0	0	0	0
125	60°	A	-51387	0	-95369	-86149	0	-105204	-434184	0	107231
		B	0	0	0	0	0	0	0	0	0
125	90°	A	31521	0	-111850	-184527	0	71629	98626	0	-101198
		B	0	0	0	0	0	0	0	0	0
125	120°	A	57259	0	-98745	-143536	0	93516	210274	0	-122435
		B	0	0	0	0	0	0	0	0	0
125	150°	A	96453	0	-59299	8983	0	42922	132276	0	-32333
		B	0	0	0	0	0	0	0	0	0
125	180°	A	110260	0	-4215	51766	0	32671	122152	0	-10291
		B	0	0	0	0	0	0	0	0	0

Table 2A. Foundation Loading Moment Table for 3.6-/3.7-Meter Pipe and Flanged Pipe Mount Earth Station Antennas

Foundation Layout - Slab
3.6-/3.7-Meter
Pedestal Mount
Earth Station Antenna

Volume of Concrete
3.0 Cubic Yards
(2.3 Cubic Meters)

Weight of Reinforcing
194 Lbs
(88 Kilograms)

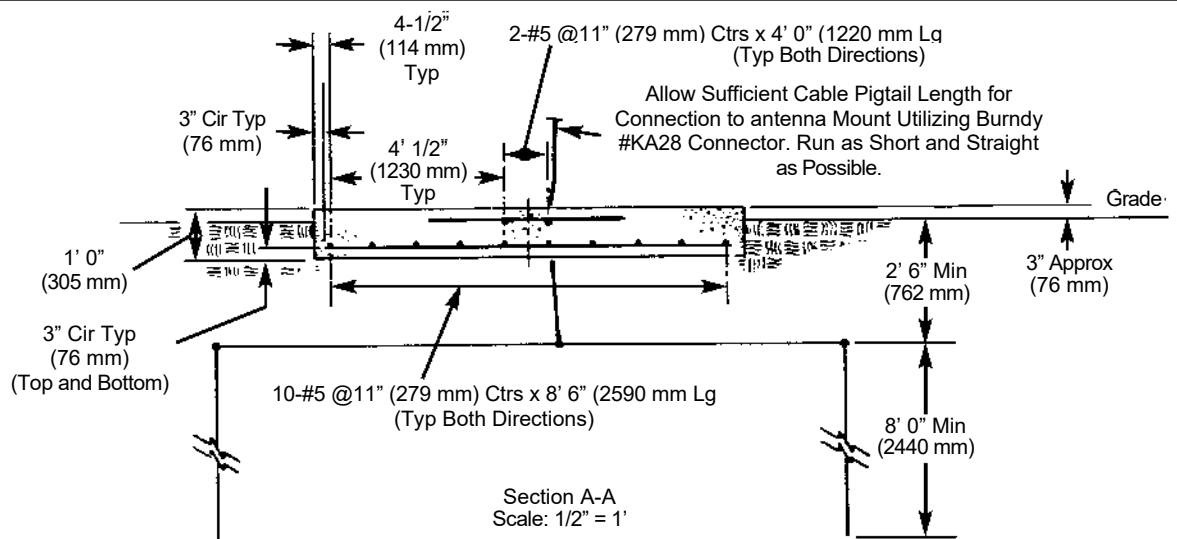
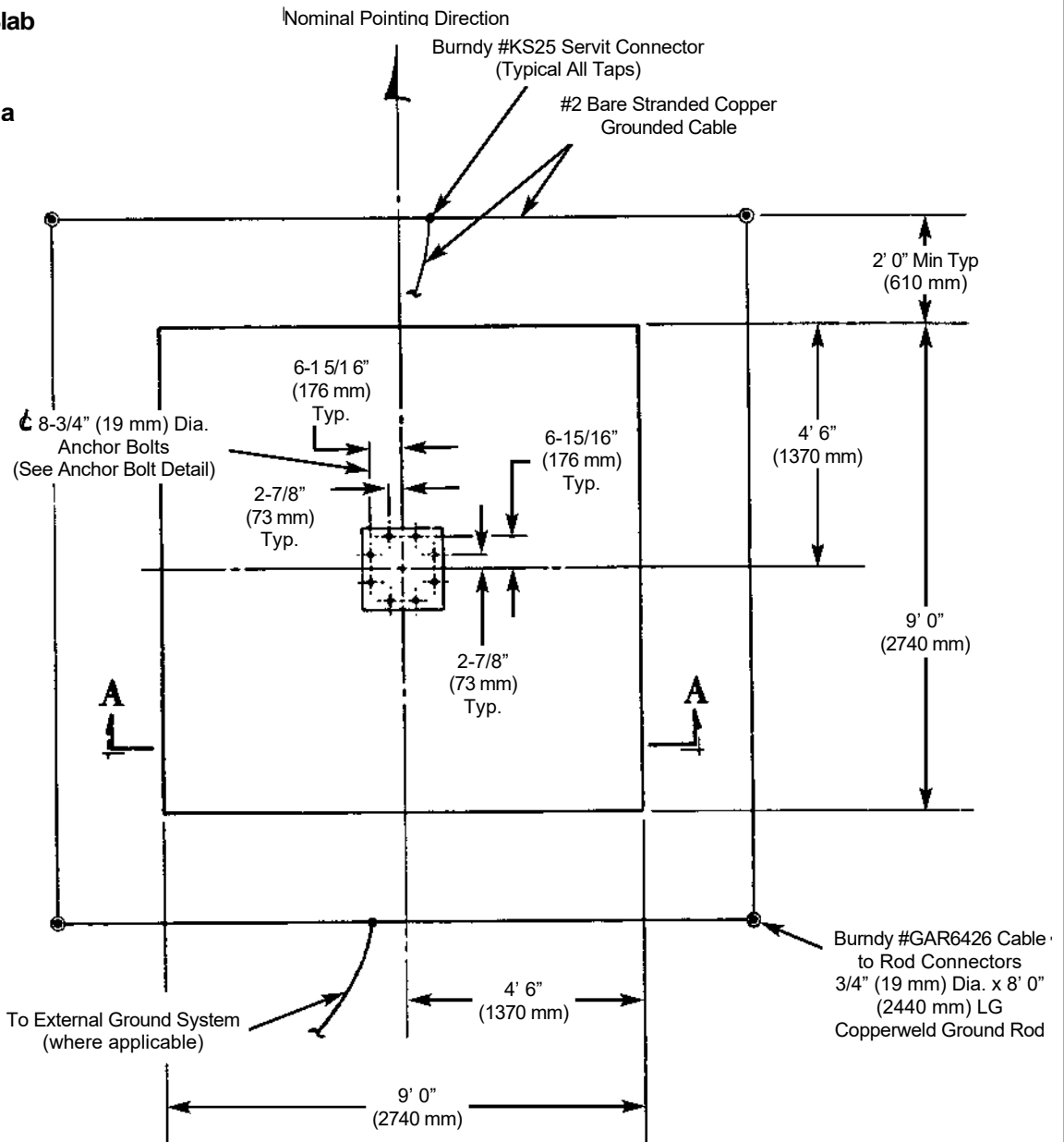

General Notes - Pedestal Mount

1. This foundation is a typical design only. Certification of its suitability for a particular installation by a professional engineer is required prior to its use for actual fabrication.
 2. All dimensions are shown in feet and inches (and millimeters).
 3. Contractor shall field verify all dimensions locating existing construction before fabrication of new construction begins.
 4. Concrete and related work shall be mixed, placed and cured in accordance with the "Building Code Requirements for Reinforced Concrete" ACI 318-89 (Rev 88) and "Specifications for Structural Concrete" ACI 301-84 (Rev 88) Publication SP-15 (88).
 5. Concrete shall develop a compressive strength of at least 3000 psi (211 kgf/cm²) in 28 days with a maximum slump of 3" (76 mm) at time of placing.
 6. Reinforcing bars shall conform to ASTM A61 5 (S1) grade 60 deformed type $F_y = 60,000$ psi (4,220 kgf/cm²).
 7. Unless otherwise noted, concrete cover for reinforcing bars shall conform to the minimum requirements of ACI 318-89 (Rev 88).
 8. Fabrication of reinforcing steel shall be in accordance with the "Manual of Standard Practice for Detailing Reinforced Concrete Structures" ACI 315-80 (Rev 86).
 9. Provide 3/4" (19 mm) x 45° chamfer on all exposed concrete edges.
 10. Foundations have been designed to rest on undisturbed soil (per EIA-41 1-A and RS-222-E) with a minimum allowable net vertical bearing capacity of 2000 psf (9770 kgf/m²). If undesirable soil conditions are encountered, the engineer shall be notified.
 11. Backfills shall be suitable excavated material or other suitable material compacted in 3" (76 mm) lifts to 90% of maximum density as determined by ASTM D1 557.
 12. Ground rods shall be driven to depths as shown (below permanent moisture level) and ground system resistance measured. The antenna structure shall be connected to a grounding system consisting of a number of interconnected ground rods. The system shall meet the standards of the Underwriters' Laboratories Publication No. UL96A for lightning protection. The ground rod system-to-earth resistance shall not exceed 10 Ohms at any time during the year.
 13. Grounding system shown is the minimum necessary. Local conditions will dictate grounding system design.
 14. If this foundation is to be located in an area where the annual frost penetration depth exceeds 9" (229 mm), the local building code specifying a minimum required foundation depth should be consulted.
-

Foundation Layout - Slab
3.6-/3.7-Meter
Pipe Mount
Earth Station Antenna

Volume of Concrete
5.3 Cubic Yards
(4.3 Cubic Meters)

Weight of Reinforcing
353 Lbs
(160 Kilograms)

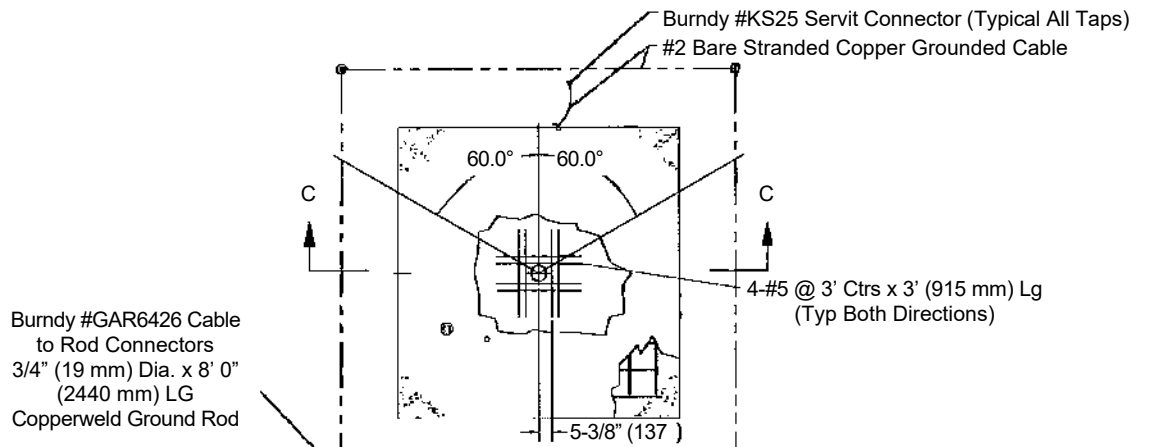
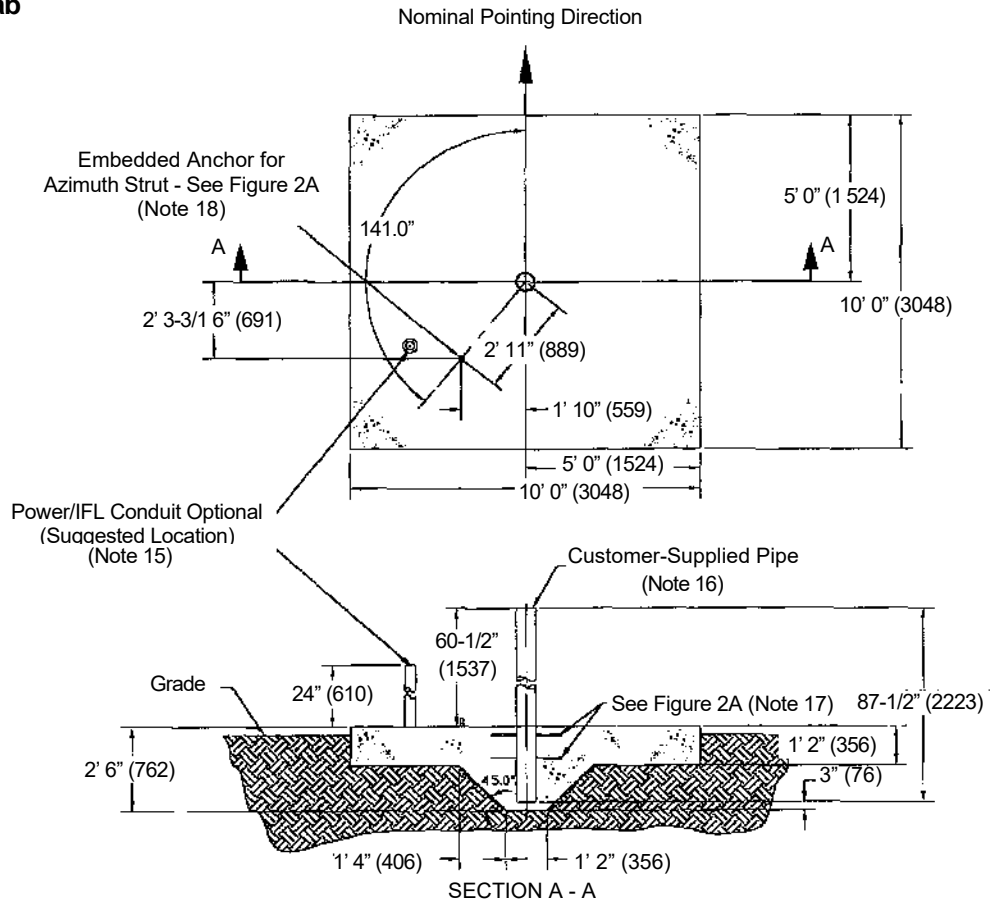

Allow Sufficient Cable Pigtail Length for Connection to antenna Mount Utilizing Burndy #KA28 Connector. Run as Short and Straight as

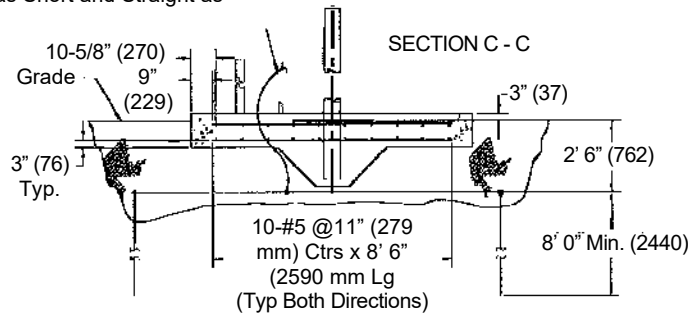

Figure 3A

General Notes - Embedded Pipe Mount

1. This foundation is a typical design only. Certification of its suitability for a particular installation by a professional engineer is required prior to its use for actual fabrication.
2. All dimensions are shown in feet and inches (and millimeters).
3. Contractor shall field verify all dimensions locating existing construction before fabrication of new construction begins.
4. Concrete and related work shall be mixed, placed and cured in accordance with the "Building Code Requirements for Reinforced Concrete" ACI 318-89 and "Specifications for Structural Concrete" ACI 301-84 Publication SP-15.
5. Concrete shall develop a compressive strength of at least 3000 psi (211 kgf/cm sq) in 28 days with a maximum slump of 3" (76 mm) at the time of placing.
6. Reinforcing bars shall conform to ASTM A-615 (51) Grade 60 deformed type $f_y = 60,000$ psi (4,220 kgf/cm sq)
7. Unless otherwise noted, concrete cover for reinforcing bars shall conform to the minimum requirements of ACI 315-80.
8. Fabrication of reinforcing steel shall be in accordance with the "Manual of Standard Practice for Detailing Reinforced Concrete Structures" ACI 315-74.
9. Provide 3/4" (19mm) x 45° chamfer on all exposed concrete edges.
10. Foundations have been designed to rest on undisturbed soil with a minimum allowable bearing capacity of 2000 psf (9770 kgf/m sq). If undesirable soil conditions are encountered, the engineer shall be notified.
11. Backfills shall be suitable excavated material or other suitable material compacted in 3" (76 mm) lifts to 90% of maximum density as determined by ASTM D1557.
12. Ground rods shall be driven to depths as shown (below permanent moisture level) and ground system resistance measured. The antenna structure shall be connected to a grounding system consisting of a number of interconnected ground rods. The system shall meet the standards of the Underwriters' Laboratories Publication no. UL96A for lightning protection. The ground rod system-to-earth resistance shall not exceed 10 Ohms at any time during the year.
13. Grounding system shown is the minimum necessary. Local conditions will dictate grounding system design.
14. If this foundation is to be located in an area where the annual frost penetration depth exceeds 9" (229 mm) the local building code specifying a minimum required foundation depth should be consulted.
15. Electrical/IFL power - Drawing depicts suggested location for electrical power conduit to antenna. Size, type and depth to bury conduit to be determined by customer in compliance with local codes. Direction to route conduit to be determined by the relative location of communications building/shelter. Power conduit to extend 6" (minimum) above surface of foundation slab. Open ends of conduit to be sealed to prevent moisture and foreign particle contamination.
16. Customer-supplied pipe:
6" (152) nominal double extra strong steel pipe per ASTM A53, Grade B, Type E, or equivalent (actual O.D. 6-5/8" (168), 0.864" (21 .9) wall thickness), 87-1/2" (2223 long, hot dip galvanized per ASTM A123. Pipe must be filled with concrete for additional stiffness.
17. Holes to be drilled (or torched) through both walls of pipe and 24' (610) long sections of #5 rebar inserted through holes and centered, rebar sections to be welded to pipe. Provide this in 2 places to be tied into main rebar grid.
18. The position shown for the embedded azimuth strut anchor will provide of azimuth travel in $\pm 7.5^\circ$ sections from the nominal antenna pointing direction. Additional anchors can be embedded to accommodate additional nominal antenna pointing directions.

Foundation Layout - Slab
3.6-/3.7-Meter
Flanged Pipe Mount
Earth Station Antenna

Volume of Concrete
3.8 Cubic Yards
(3.0 Cubic Meters)

Weight of Reinforcing
90 Lbs
(41 Kilograms)

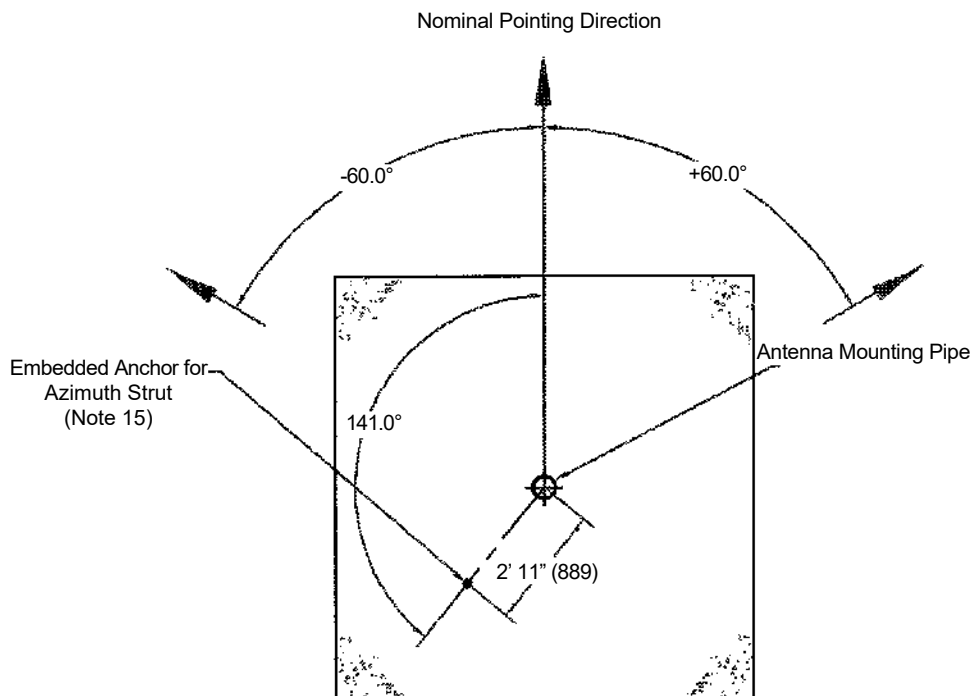
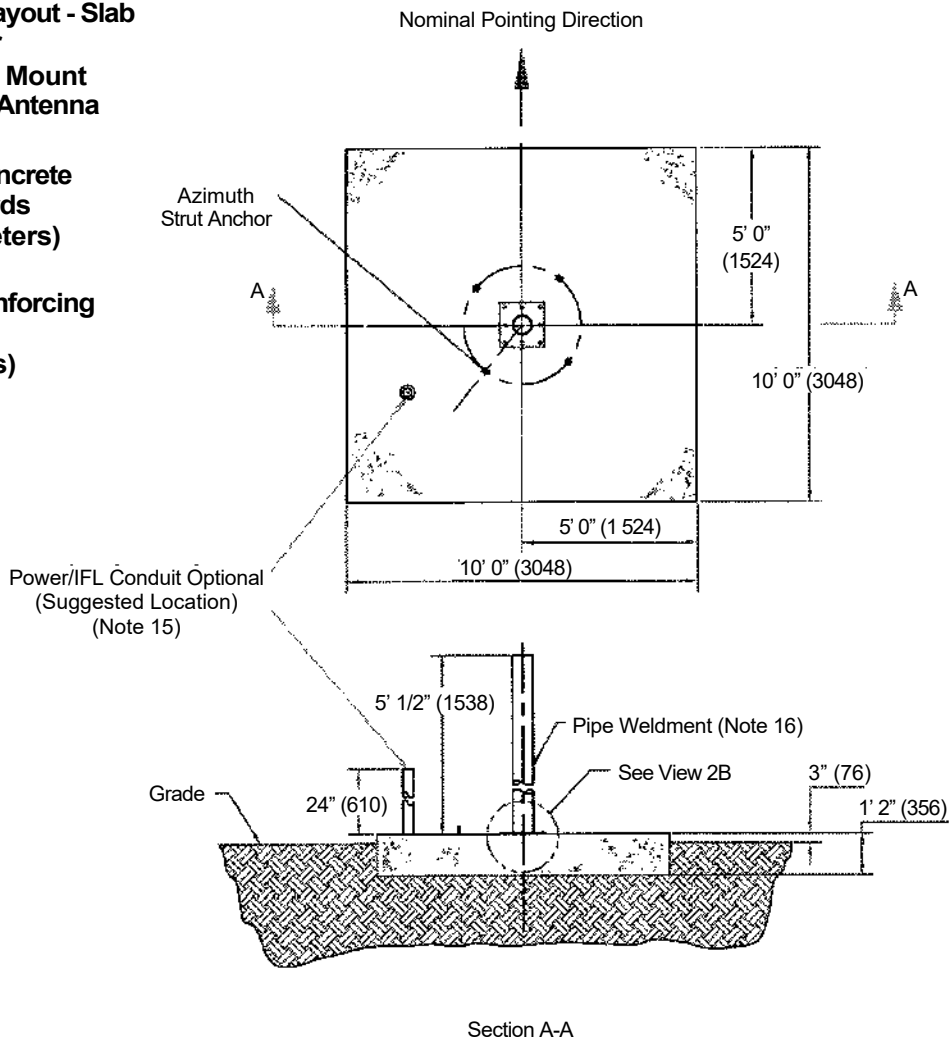

General Notes - Flanged Pipe Mount

1. This foundation is a typical design only. Certification of its suitability for a particular installation by a professional engineer is required prior to its use for actual fabrication.
 2. All dimensions are shown in feet and inches (and millimeters).
 3. Contractor shall field verify all dimensions locating existing construction before fabrication of new construction begins.
 4. Concrete and related work shall be mixed, placed and cured in accordance with the "Building Code Requirements for Reinforced Concrete" ACI 318-89 and "Specifications for Structural Concrete" ACI 301-84 Publication SP-15.
 5. Concrete shall develop a compressive strength of at least 3000 psi (211 kgf/cm sq) in 28 days with a maximum slump of 3" (76 mm) at the time of placing.
 6. Reinforcing bars shall conform to ASTM A-615 (51) Grade 60 deformed type $f_y = 60,000$ psi (4,220 kgf/cm sq)
 7. Unless otherwise noted, concrete cover for reinforcing bars shall conform to the minimum requirements of ACI 315-80.
 8. Fabrication of reinforcing steel shall be in accordance with the "Manual of Standard Practice for Detailing Reinforced Concrete Structures" ACI 315-74.
 9. Provide 3/4" (19mm) x 45° chamfer on all exposed concrete edges.
 10. Foundations have been designed to rest on undisturbed soil with a minimum allowable bearing capacity of 2000 psf (9770 kgf/m sq). If undesirable soil conditions are encountered, the engineer shall be notified.
 11. Backfills shall be suitable excavated material or other suitable material compacted in 3" (76 mm) lifts to 90% of maximum density as determined by ASTM D1557.
 12. Ground rods shall be driven to depths as shown (below permanent moisture level) and ground system resistance measured. The antenna structure shall be connected to a grounding system consisting of a number of interconnected ground rods. The system shall meet the standards of the Underwriters' Laboratories Publication no. UL96A for lightning protection. The ground rod system-to-earth resistance shall not exceed 10 Ohms at any time during the year.
 13. Grounding system shown is the minimum necessary. Local conditions will dictate grounding system design.
 14. If this foundation is to be located in an area where the annual frost penetration depth exceeds 9" (229 mm) the local building code specifying a minimum required foundation depth should be consulted.
 15. Electrical/IFL power - Drawing depicts suggested location for electrical power conduit to antenna. Size, type and depth to bury conduit to be determined by customer in compliance with local codes. Direction to route conduit to be determined by the relative location of communications building/shelter. Power conduit to extend 6" (minimum) above surface of foundation slab. Open ends of conduit to be sealed to prevent moisture and foreign particle contamination.
 16. Customer-supplied pipe:
6" (152) nominal double extra strong steel pipe per ASTM A53, Grade B, Type E, or equivalent (actual O.D. 6-5/8" (168), 0.864" (21.9) wall thickness), 60-1/2" (1537 long, hot dip galvanized per ASTM A123. Pipe must be filled with concrete for additional stiffness with 1" (25.4) welded flange.
 17. The position shown for the embedded azimuth strut anchor will provide of azimuth travel in $\pm 7.5^\circ$ sections from the nominal antenna pointing direction. Additional anchors can be embedded to accommodate additional nominal antenna pointing directions.
-

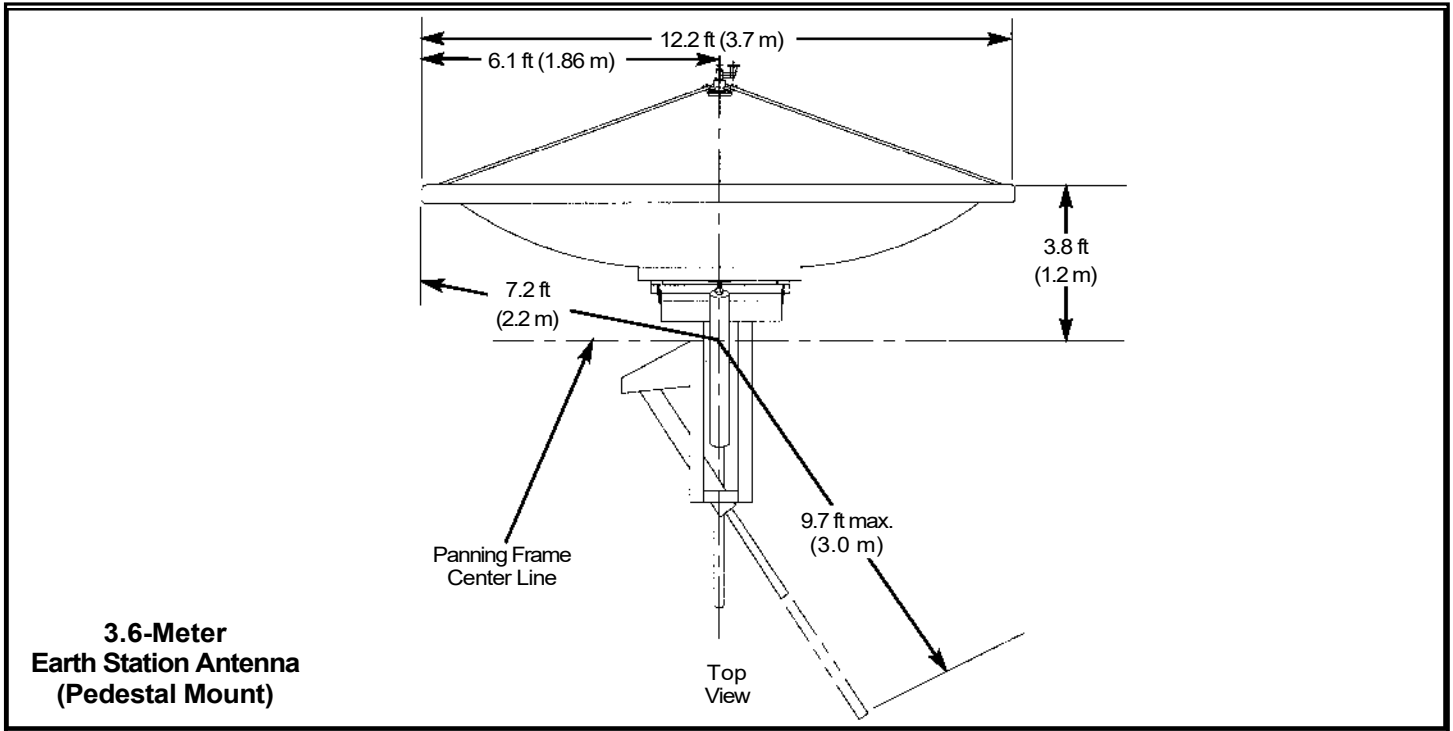

Figure 4

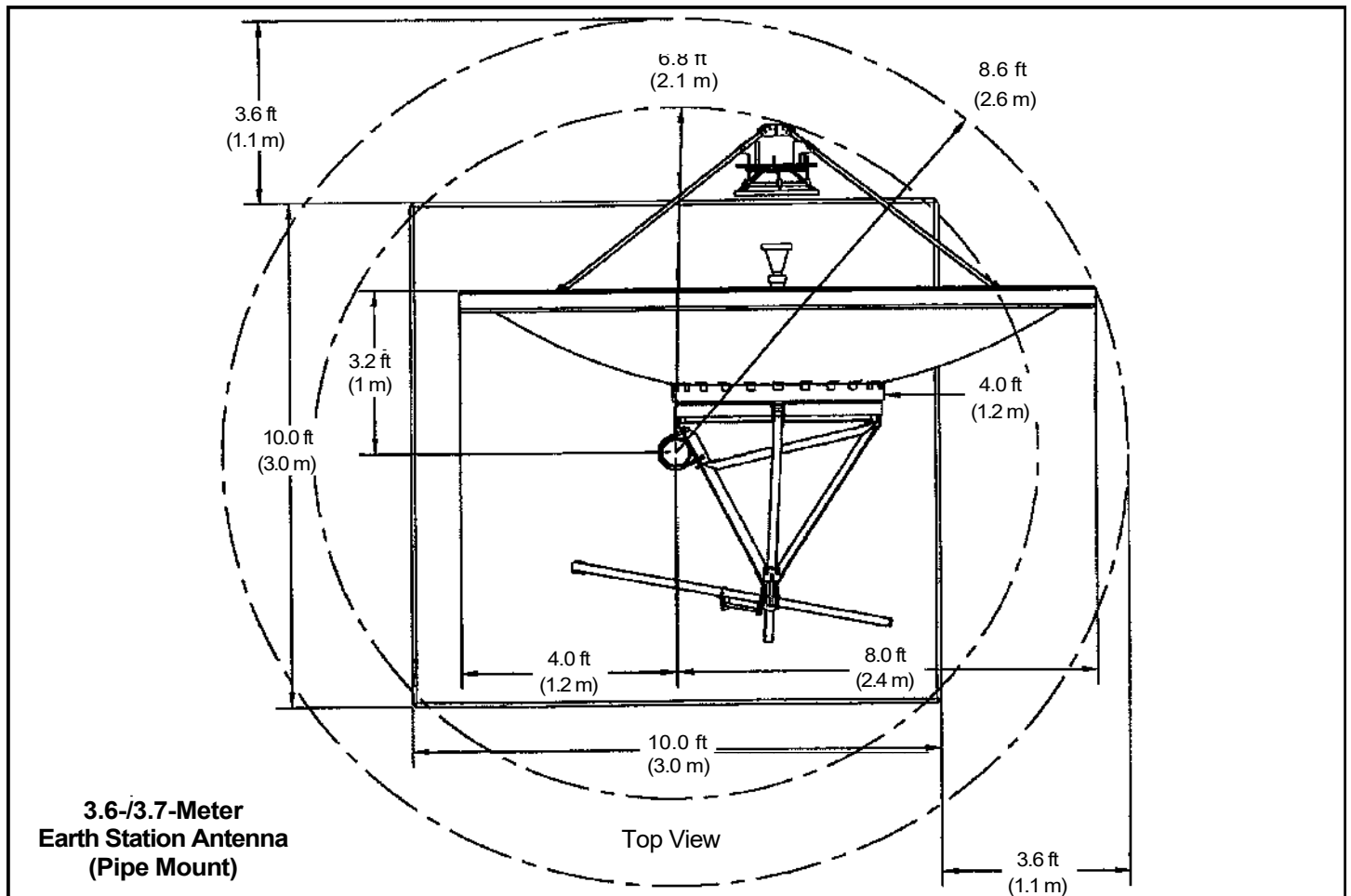

Figure 4A

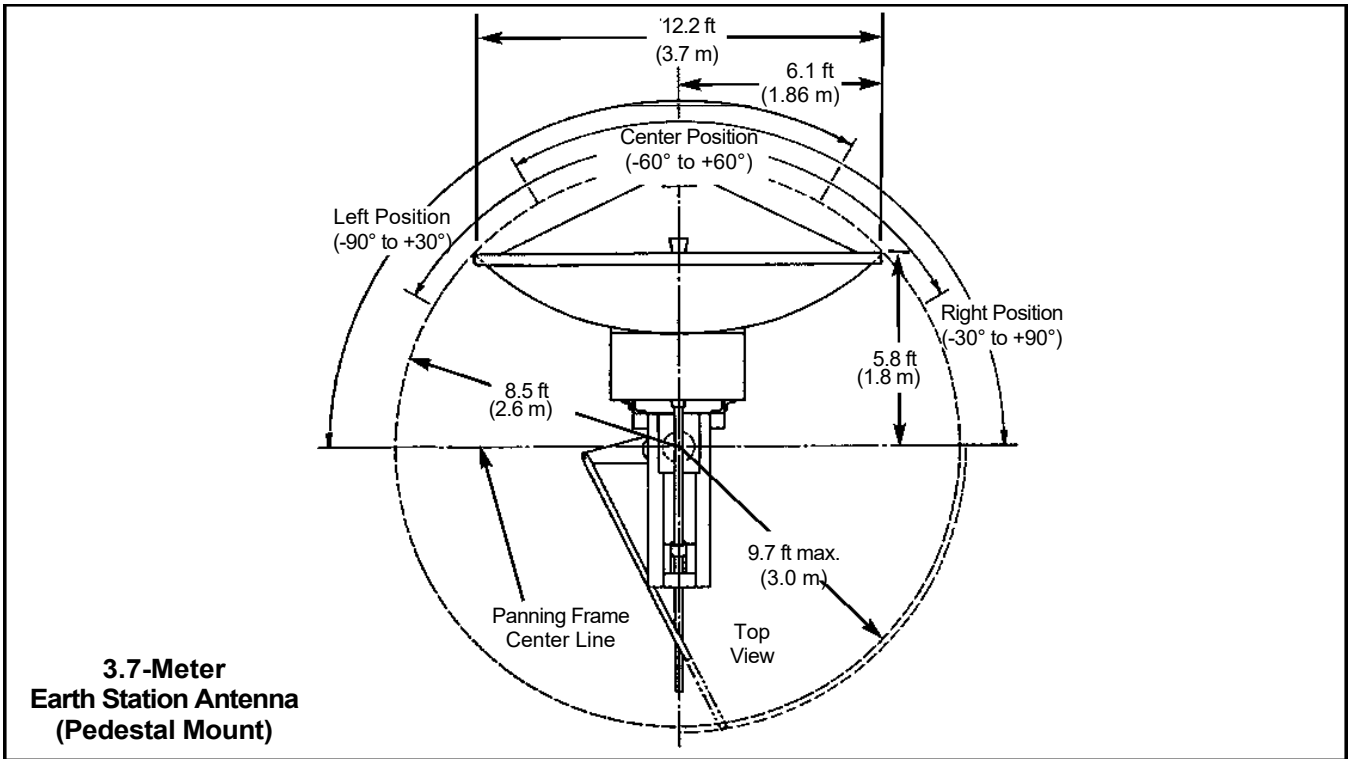

Figure 5

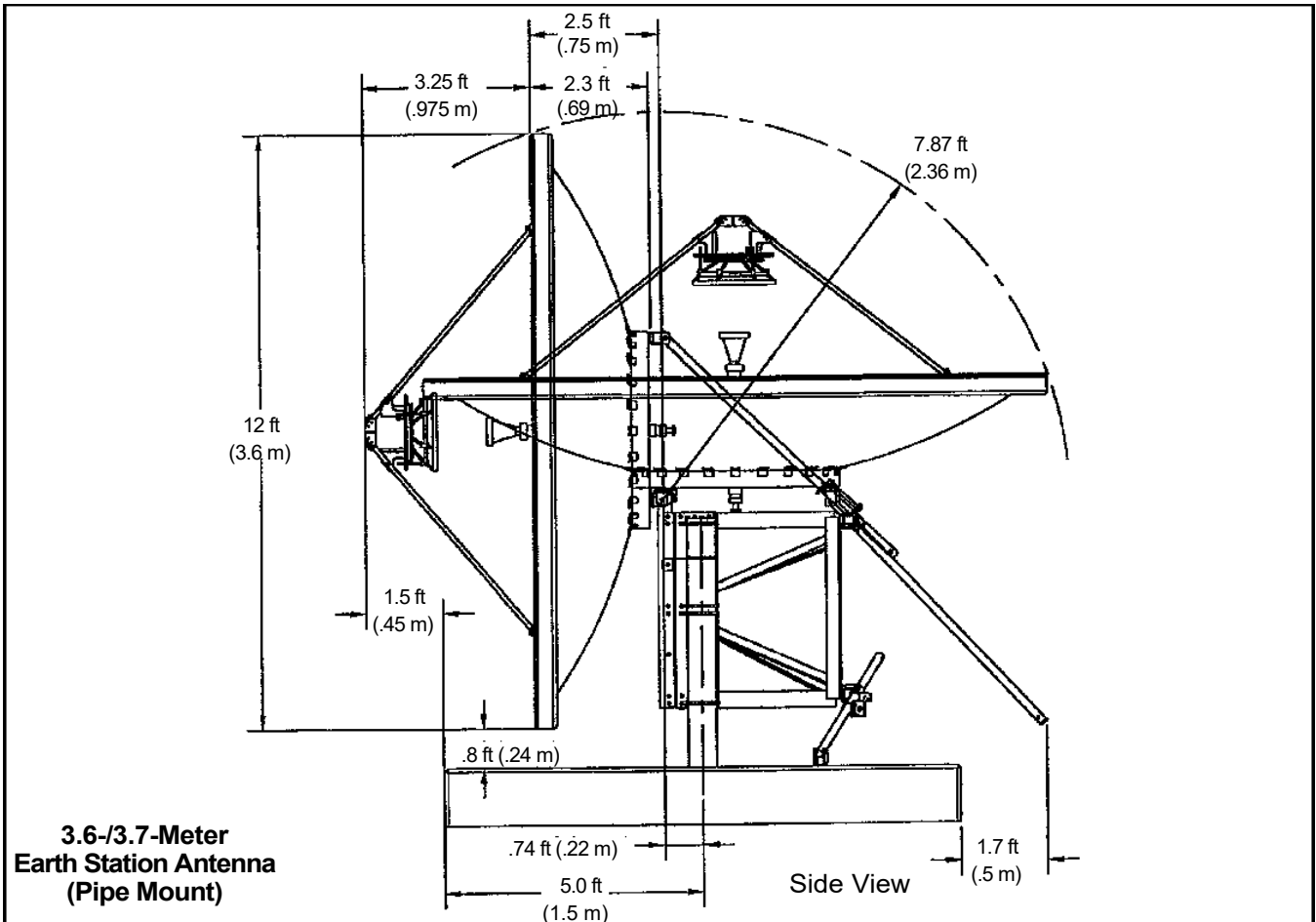

Figure 5A

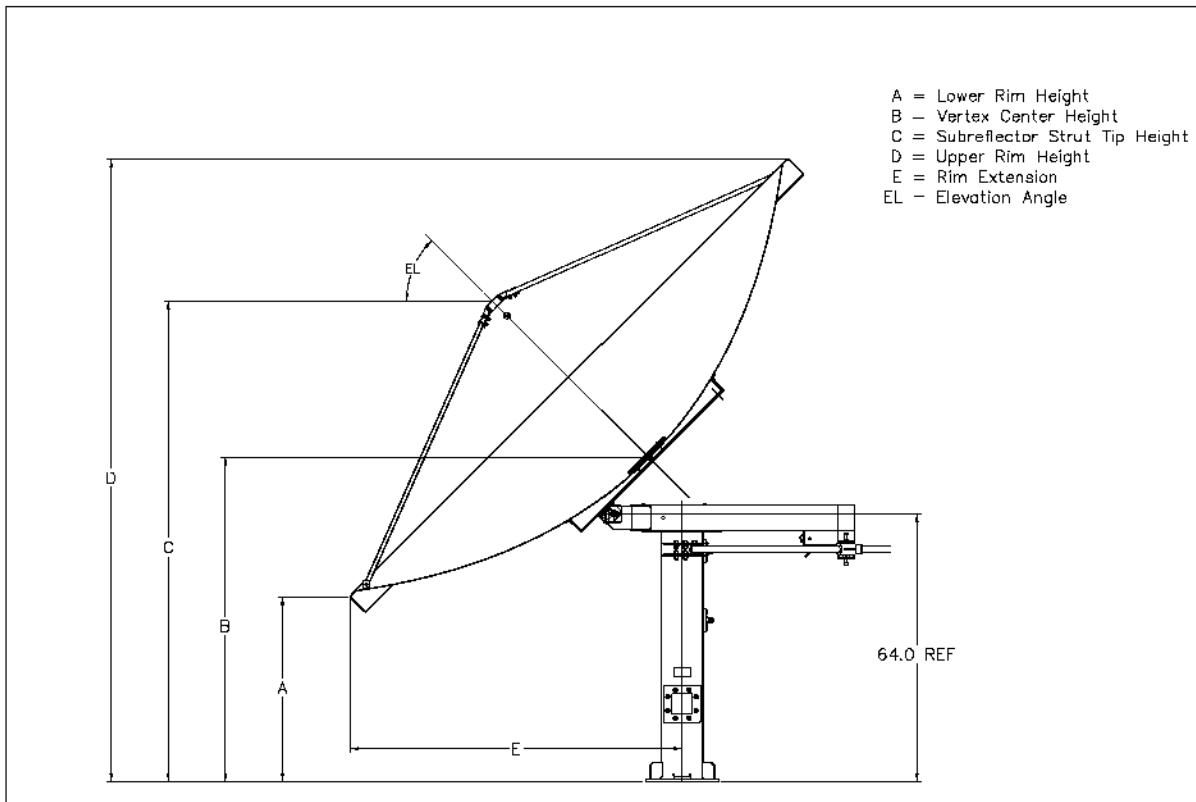

Figure 6 – Manual 3.6m Pedestal Mount

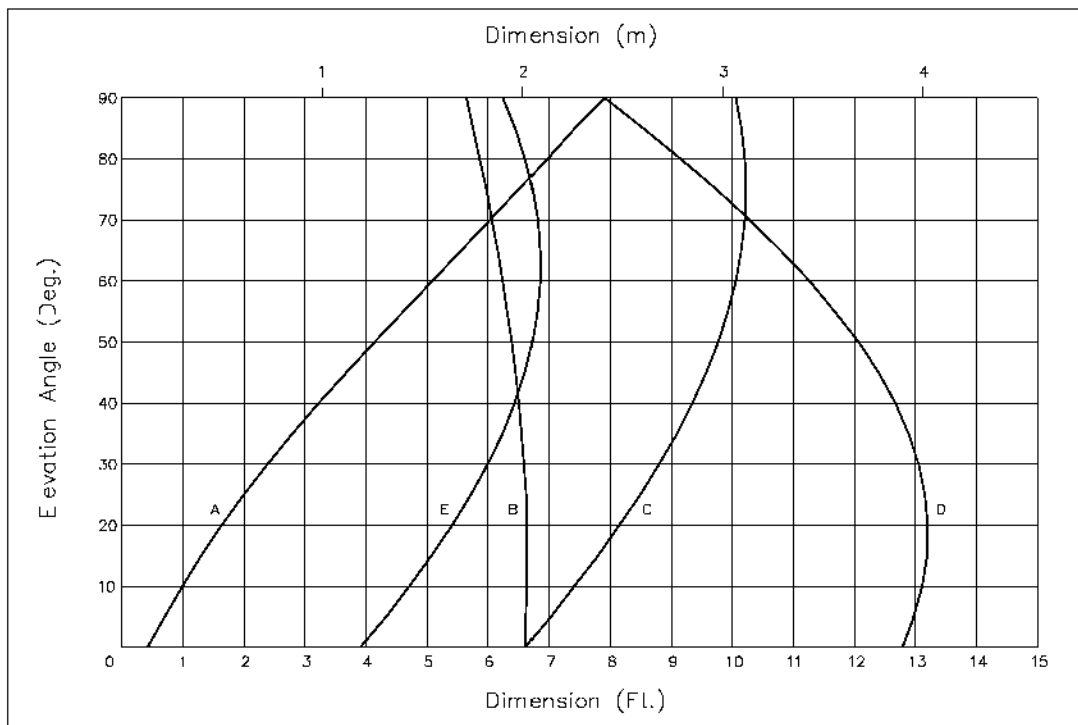

Figure 6a – Manual 3.6m Pedestal Mount

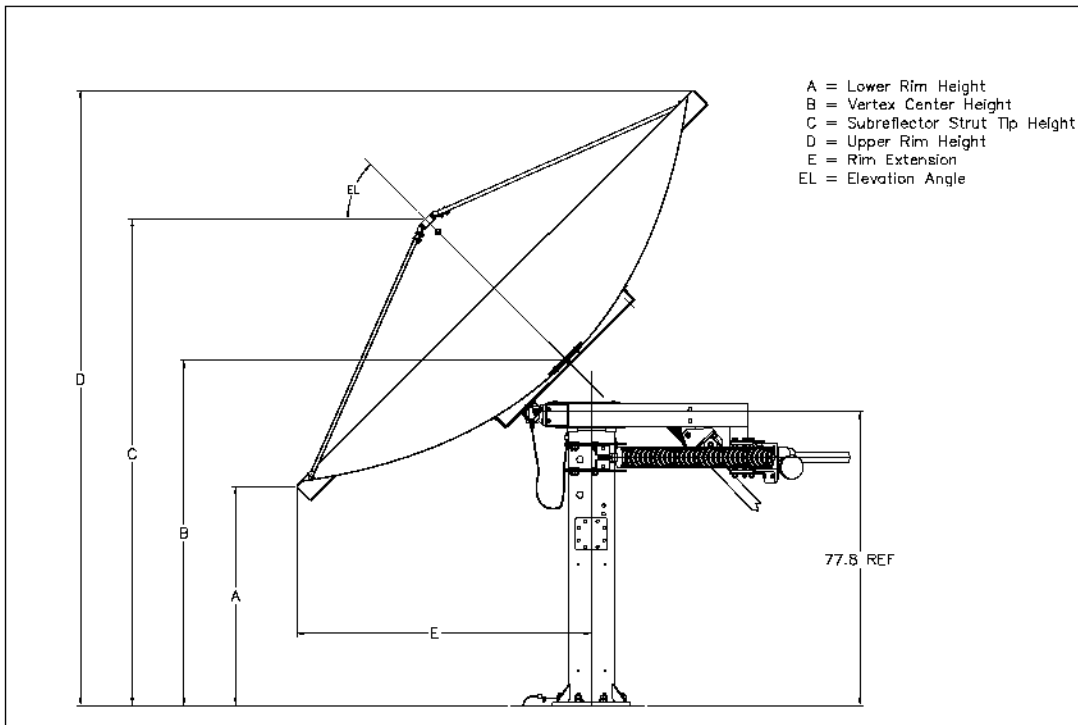

Figure 7 – Motorizeable 3.6m Pedestal Mount

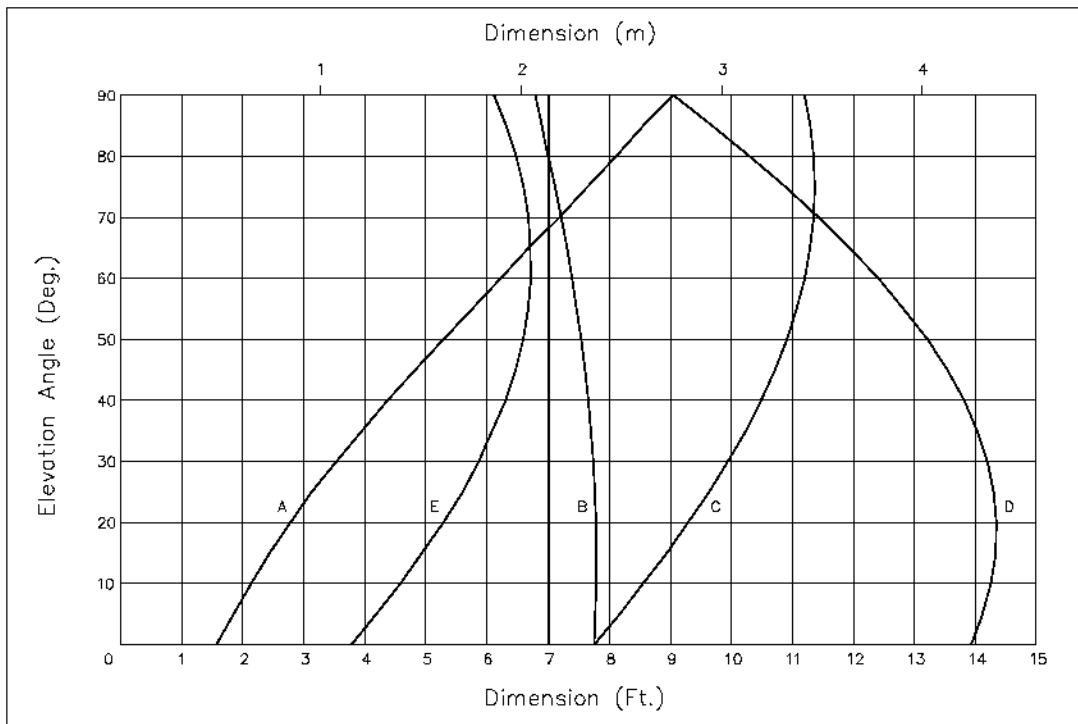

Figure 7a – Motorizeable 3.6m Pedestal Mount

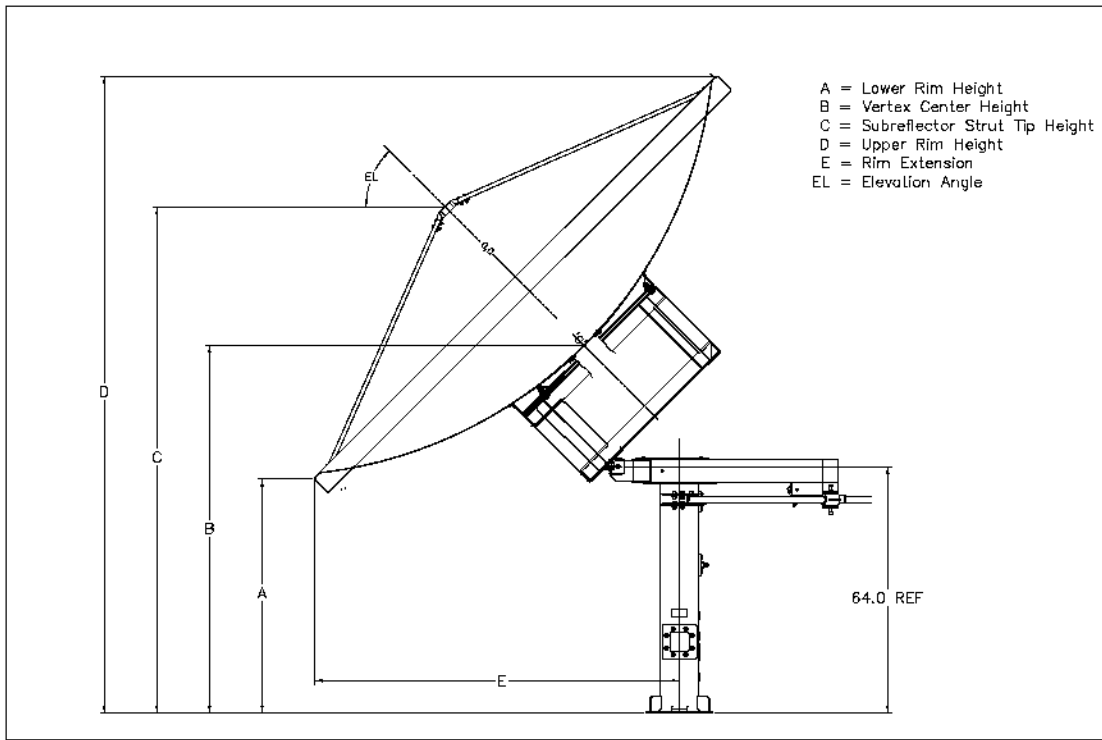

Figure 8 – Manual 3.7m Pedestal Mount

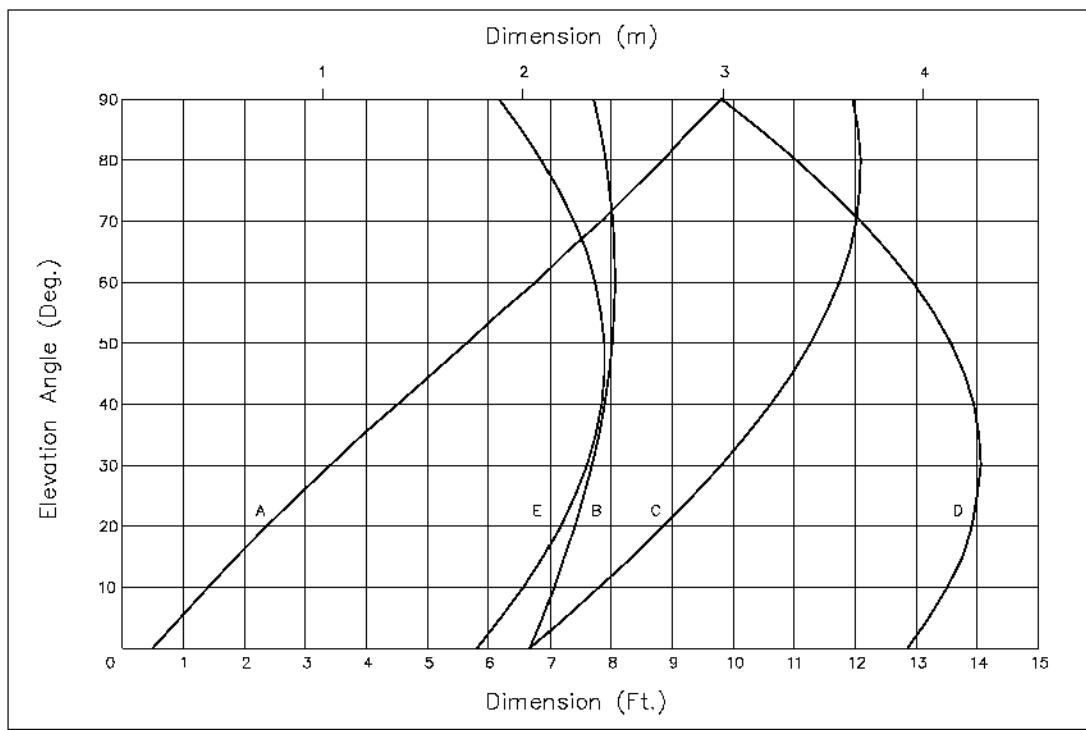

Figure 8a- Manual 3.7m Pedestal Mount

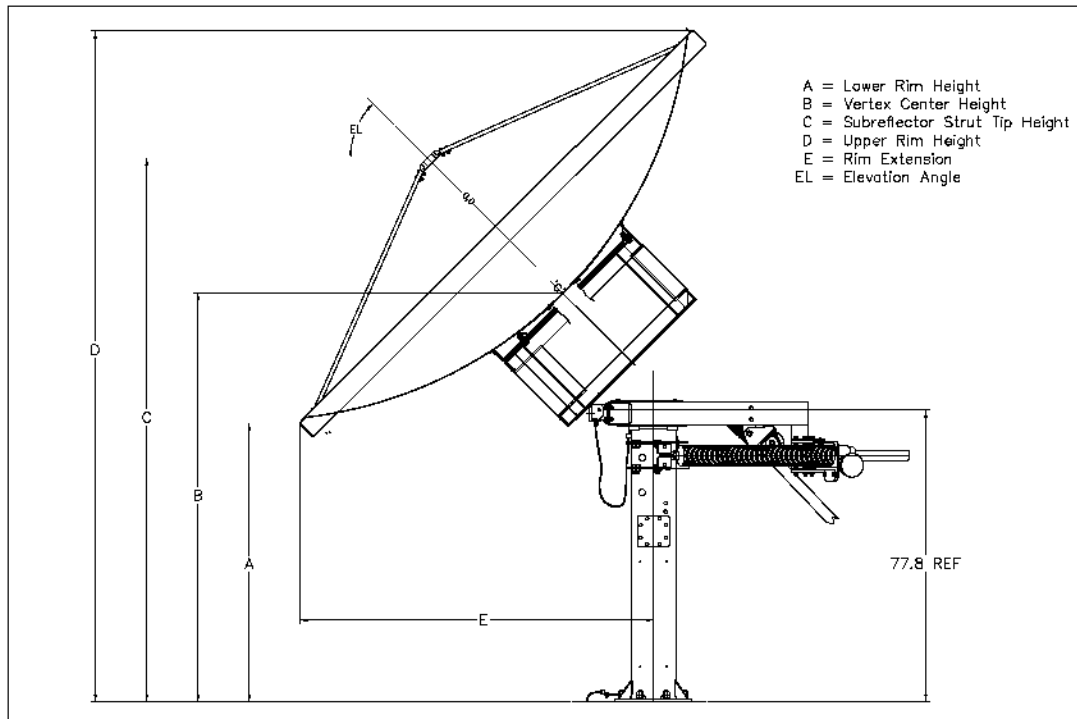

Figure 9 – Motorizeable 3.7m Pedestal Mount

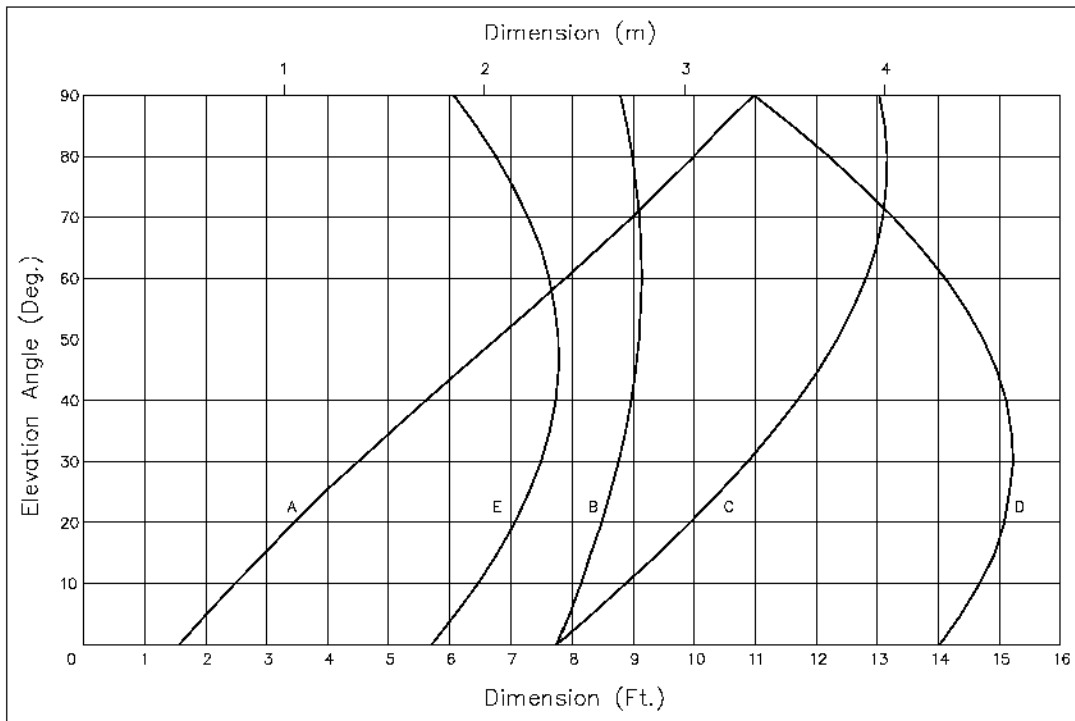

Figure 9a – Motorizeable 3.7m Pedestal Mount

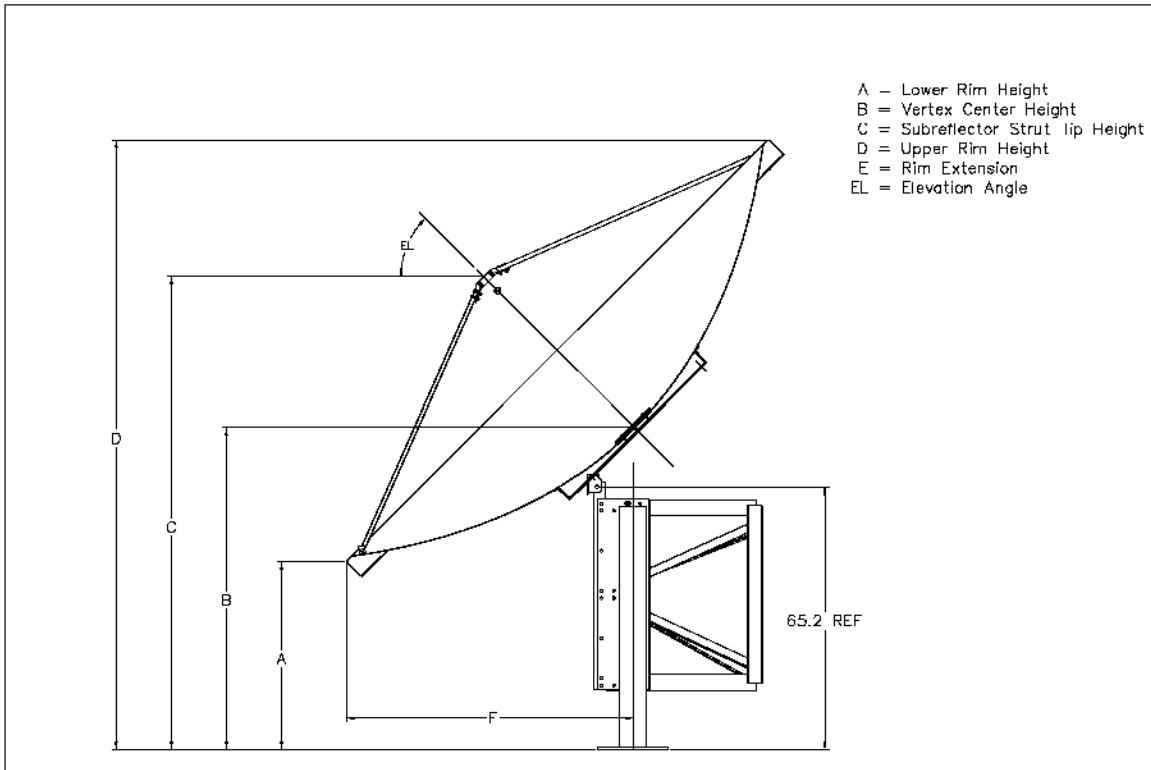

Figure 10 – Manual 3.6m Pipe Mount

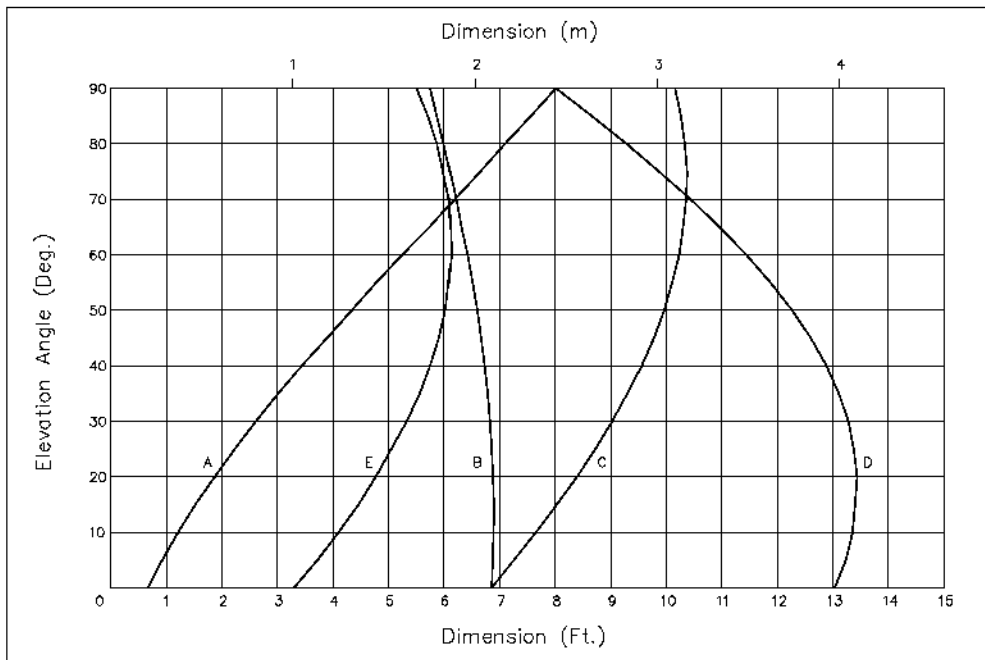

Figure 10a – Manual 3.6m Pipe Mount

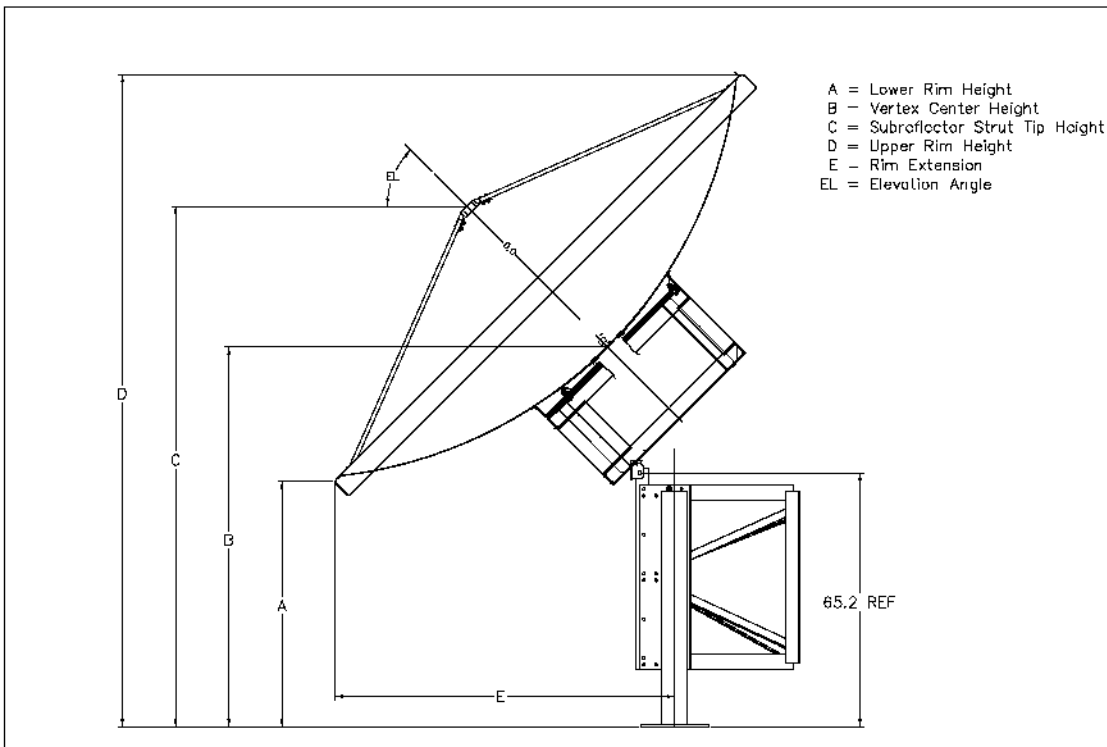

Figure 11 – Manual 3.7m Pipe Mount

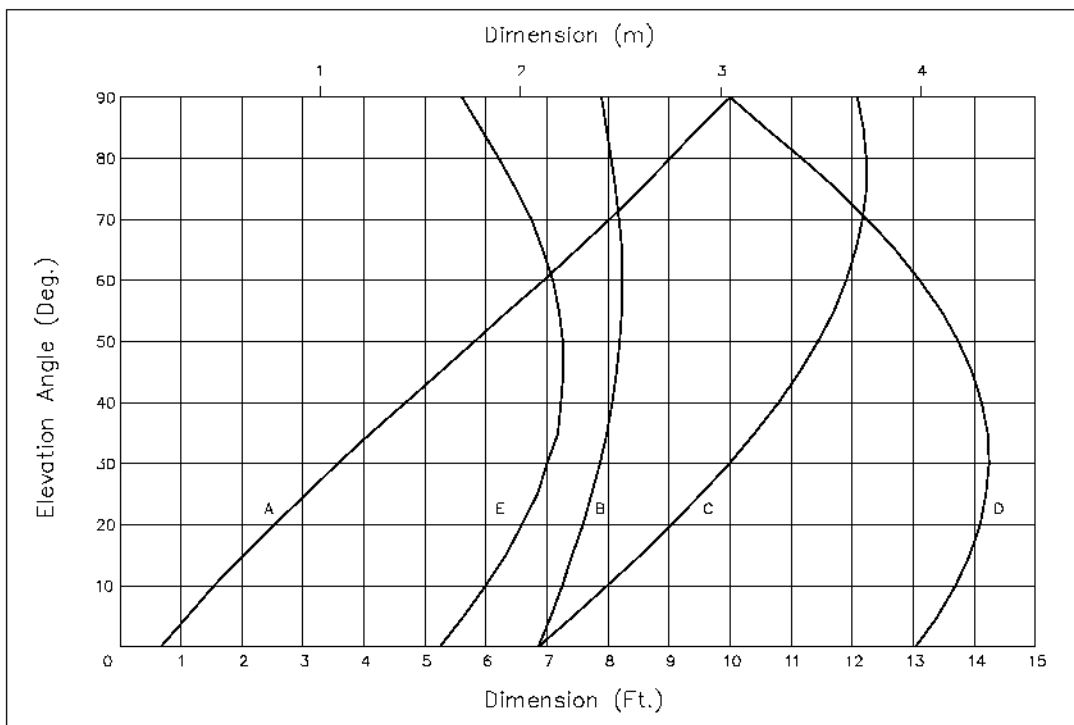

Figure 11a – Manual 3.7m Pipe Mount