



# 9.4M EARTH STATION ANTENNA

## Assembly, Installation, Operation & Maintenance Manual

Kratos Antenna Solutions Corporation

Kratos Antenna Solutions Corporation  
3801 E. Plano Parkway Suite 200  
Plano, TX 75074  
USA  
[www.KratosDefense.com](http://www.KratosDefense.com)  
Tel: 214-291-7654  
Fax: 214-291-7655

CAGE CODE

4ZTA9

Manual# OM94 – Revision V

**This page intentionally left blank.**

Copyright 2023 Kratos Defense & Security Solutions, Inc.

All Rights Reserved. No part of this document may be photocopied, reproduced, stored in a retrieval system, or transmitted, in any form or by any means whether electronic, mechanical, or otherwise without the prior written permission of *Kratos Defense & Security Solutions, Inc.*

*Kratos Defense & Security Solutions, Inc.* reserves the right to change details in this publication without notice.

#### Trademark Notices

Any and all products and companies named herein are the trademarks of their respective creators and/or owners.

#### Open Source Software Notice

This product makes extensive use of Open Source Software (OSS), including but not limited to the operating system, network agents, user interface shells, and tools used to develop the software. This software gives you the benefit of a large base of well-tested and feature-rich system software while lowering the expense of providing these features to you. It also carries certain obligations.

Some of this software is licensed by the GNU General Public License (GPL), which requires that all modifications or additions to the source code be kept public, and that the licensee continues to make the source code covered public. None of this source code has been modified for use in this product. If you are a user of this product who desires a copy of any source code covered by the GPL, contact our technical support and we will provide this free of charge through an agreeable medium. We expect all source code archives will be posted to public FTP servers. At the time of this writing, the exact address is not known. Be advised that this is a large archive. We may recommend you obtain it from the source we obtained it from, as the source may be using more recent versions. We will always supply it ourselves if you prefer.

Some of this software is licensed by the GNU Lesser General Public License (LGPL), which requires that modifications be kept public but does not require proprietary source code linked to LGPL'ed libraries be made public. None of this code has been modified for use in this product. All of the required source code will be conveyed along with the code covered by the GPL above.

Some of this software is licensed by variations of the Berkeley Software Distribution (BSD) license, which do not require us to pass on source code. Some of this software has been modified for use in this product. However, in the spirit of open source, the original code will be supplied in the same manner as the code covered by the GPL on request.

Please be advised that you will incur the same responsibilities we have incurred if you choose to redistribute any or all of the source codes obtained through this method. Please read the included license documents carefully.

If you have any questions about our interpretation of our obligations under OSS licenses, do not hesitate to contact us. Our intent is to comply fully with all licensing obligations.

©Kratos Defense & Security Solutions, Inc.

[www.KratosDefense.com](http://www.KratosDefense.com)

## REVISION HISTORY

REVISION LEVEL	DESCRIPTION OF CHANGE
Rev. A Original Issue: June 2009	This is the original release of this manual.
Rev. B:	Updated Document
Rev. C:	Updated Document
Rev. D:	Updated Document
Rev. E:	Updated Document
Rev. F:	Updated Document
Rev. G:	Updated Document
Rev. H:	Updated Document
Rev. J: June 2016	Updated format.
Rev. K: May 2017	Change Trichloroethylene & Lacquer Thinner to Acetone
Rev. L: Aug 2018	Modify Table 4-2, added lube spec for <i>El Jackscrew Gear Housing</i> . Spec for <i>Az Gear Housing</i> was MobilGear 629-12.8 liters (12mo. Freq.)
Rev. M: Oct 2018	Update wind loading information
Rev. N: Sept 2019	Update Table 1-2 Door Enclosure information. Update brake maintenance information.
Rev. P: June 2020	Updated Document
Rev. R: Sept. 2020	Updated for 4-pt hub change
Rev. T: July 2021	Updated company name and address.
Rev. U: Sept 2022	Updated Lubrication of Gear Motor/Housing
Rev. V: Sept 2023	Updated Tech Support information

## ABOUT THIS MANUAL

### Purpose

The scope of this manual is intended to provide station personnel with the base installation, operation, and maintenance requirements necessary for a 9.4-Meter C-, X-, or Ku-/Ka-Band Earth Station Antenna (9.4m ESA). This manual provides a convenient reference for authorized operator/service personnel requiring technical information on general system or specific subsystem equipment.

**NOTE: All antenna option instructions are included in the individual kit shipped with that part.**

Top Level Assembly Numbers are as follows:

ES94K-1: 9.4m ESA Ku- and K-Band. Motorizable Pedestal Mount with Az & El Jackscrews.

ES94KAA-1: 9.4m ESA Ka-Band. Non-motorized/Partially Motorizable Pedestal Cap Mount with Pipes Struts.

ES94MPEXKA-1: 9.4m ESA Ku-,K-, and Ka-Band. Motorizable Extended Azimuth Pedestal Mount with Dual drive Az and Dual El Jackscrews.

**WARNING: FOR DETAILED SAFETY INFORMATION, REFER TO THE NGC SAFETY GUIDELINES & PERSONNEL RESTRICTIONS DOCUMENT PROVIDED WITH THE NGC DOCUMENTATION PACKAGE.**

### Installation Notice

Installation, maintenance, or removal of the hardware described in this manual requires qualified and experienced personnel. Kratos installation instructions are written for such personnel. Qualified personnel **MUST** perform proper installation and maintenance of the equipment, and **MUST** verify the condition of the equipment at initial installation and periodically thereafter.

**NOTE: Kratos is NOT liable or responsible for results of improper or unsafe installation and maintenance practices. All designs, specifications, and availability of products are subject to change without notice.**

### What to Know When You See OPTION:

Any time you see OPTION: this means that the information following it is related to an optional element (in either hardware or software) that may or may not apply to the arrangement of your particular NGC Unit. Please note that if you see an option that you do not have but would like to purchase, please contact Kratos.

### Overview

The installation, operation, and maintenance of the 9.4m ESA require qualified and experienced personnel. Kratos installation, operation, and maintenance instructions are illustrated for such personnel. Additionally, the antenna should be inspected by qualified personnel to verify proper installation, maintenance, and condition of equipment as described in Preventive Maintenance. The basic equipment and accessories are either manufactured or design controlled by Kratos.

The prerequisite information necessary for the 9.4m ESA can be found in this section. Furthermore, this section should be reviewed before performing the installation, operation, or maintenance. Warnings, recommended tools, and the antenna parts can be verified and/or determined with such a review.

### General Product Description

The 9.4m ESA provides high gain and exceptional pattern characteristics. The electrical performance and exceptional versatility provide the ability to configure the antenna with your choice of combining network. That versatility is provided at the time of initial purchase, as well as in the future, as your satellite communication requirements evolve.

The aluminum reflector is precision formed for accuracy and strength, requiring minimal assembly. The reflector assembly is 31-feet (9.4-meters) in diameter and segmented in a twenty-panel configuration to reduce shipping volume and facilitate transport to remote sites. Reflector panels are conversion coated and painted with a flat white paint.

The versatile pedestal mount can be purchased with motorizable capabilities. The pedestal mount features over 180° Azimuth coverage in continuous 120° overlapping ranges and executes 90° (0-90°) continuous Elevation adjustment. This large adjustment range provides non-critical foundation orientation and the ability to view geostationary satellites from horizon-to-horizon, from any location worldwide.

The motorizable pedestal mount features self-aligning bearings for the Elevation pivots, resulting in "zero" backlash. This mount can be operated manually, but has the ability to be upgraded for motorized operation, including step-tracking or SmarTrack® applications. The Az/El jackscrews are equipped for integration with the optional motor drive systems. A cross-axis grounding kit is supplied with each mount to ensure electrical interconnectivity of the complete structure.

### **ES94MPEXKA-1**

The 9.4m Earth Station Antenna provides high gain and exceptional radiation pattern characteristics. The outstanding electrical performance and versatility provides the ability to configure the antenna with your choice of combining network.

The 9.4m antenna has incorporated Subreflector Tracking (SRT) to continuously maintain the antenna pointed at the satellite. This is also controlled by a microprocessor.

The aluminum reflector is precision formed for accuracy and strength, requiring minimal assembly time. The reflector assembly is 9.4 meters (31 feet) in diameter and segmented in a 20-piece configuration to reduce shipping volume and facilitate transport to remote sites. Reflector panels are conversion converted and coated with a flat white paint.

The versatile extended azimuth pedestal mount is provided with motorizable Elevation and Azimuth capabilities. The pedestal mount features over 220° continuous Azimuth coverage, and executes 0° - 90° continuous Elevation adjustment. This large adjustment range provides the ability to view geostationary satellites from almost any location worldwide. The Azimuth drive consists of dual high stiffness gear motors driving a four-point contact azimuth bearing with integral 130 tooth involute gear cut in the outer race. The dual azimuth drives are torque-biased to eliminate backlash. The Elevation axis has dual 20-ton, anti-backlash jack screws mechanically linked to a single elevation drive motor.

The aluminum enclosure and hot-dipped galvanized steel mount maintain pointing accuracy and ensure durability and reliability. The antenna and standard manual mount with enclosure will survive 125 mph (200 km/h) wind, in any position of operation, without sustaining damage or permanent deformation in moderate coastal/industrial areas. Severe conditions require additional protection.

*Kratos* provides complete system engineering, if required.

---

### Parts Verification

Kratos thoroughly inspects and carefully packs all equipment before shipment. If you find that there are missing or damaged components, please refer to the step-by-step instructions (located in back of this manual) on how to properly report equipment loss or damage. When you have received your order, verify that all parts contained in the shipment correspond to the parts listed on your packing slip/inventory.

### Warning Symbols

Various components of this System may display safety symbols. Be sure to use extreme caution when operating components with any of the following safety symbols:

*Certains éléments du système montreront peut-être des symboles de sécurité. Faites très attention à faire marcher tous les éléments qui tiennent les symboles de sécurité suivants:*



**WARNING! HAZARDOUS MOVING PARTS! KEEP FINGERS AND OTHER BODY PARTS AWAY!**

*AVERTISSEMENT! PIÈCES MOBILES DANGEREUSES! GARDEZ LES DOIGTS ET LES AUTRES PARTIES DU CORPS HORS D'ATTEINTE!*



**WARNING! RISK OF ELECTRIC SHOCK!**

*AVERTISSEMENT! RISQUE D'ÉLECTROCUTION!*



**WARNING! REFER TO MANUAL**

*AVERTISSEMENT! SE REFERER AU MANUEL D'UTILISATION.*

### Safety Terms Summary

The following safety terms may appear on the product:  
*Les termes de sécurité suivants peuvent apparaître sur le produit:*

**DANGER**—Indicates an immediately accessible injury hazard is present as you read the marking, and failure to take precautions could result in loss of life

**DANGER**—*Cette indication signale un risque de blessure immédiat et qui peut être mortel.*

**WARNING**—Indicates a nearby injury hazard that is not immediately accessible as you read the markings, and failure to take precautions could result in personal injury and/or loss of life

**AVERTISSEMENT**—*Cette indication signale un risque de blessure non immédiat mais qui peut être mortel.*

**CAUTION**—Indicates a potential hazard to property, including the product

**PRUDENCE**—*Indique un risque pour l'environ du produit, le produit inclus.*

The following safety symbols and terms may be used in this manual:  
*Les symboles et les termes suivants de sûreté pouvant être employés en ce manuel:*



**WARNING! Statements identify conditions & practices that could result in injury or loss of life.**

*AVERTISSEMENT! Les rapports d'avertissement identifient les conditions ou les pratiques qui pourraient avoir comme conséquence les dommages ou la perte de la vie.*

 **RISK OF ELECTRIC SHOCK!**

*RISQUE DE DÉCHARGE ÉLECTRIQUE!*

**Summary of Safety Precautions**

The following safety precautions are not related to any specific procedure, and so will not appear elsewhere in this manual. Ensure all personnel understand & apply these precautions in all phases of installation, operation, & maintenance. Failure to do so may result in loss of life.

 **KEEP AWAY FROM LIVE CIRCUITS:** Personnel must observe all applicable safety regulations at all times. Ensure power is disconnected or removed from the unit **BEFORE** replacing any components. Potential hazards may exist even though the power control switch is in OFF position. Capacitors retain electrical charges. Always **REMOVE POWER** & use test equipment to confirm a circuit is at ground potential **BEFORE** touching it. **NEVER** reach into or enter an enclosure to service or adjust the equipment until the absence of power has been confirmed.

 **DO NOT SERVICE OR ADJUST ALONE:** Under **NO** circumstances should **ANY** person reach into or enter the enclosure for the purpose of servicing or adjusting the equipment **except in the presence of someone who is capable of rendering aid** in case of an accident/emergency.

 **RESUSCITATION:** Personnel working with or near high voltage should be familiar with resuscitation methods (CPR and/or AED). CPR info may be obtained from medical personnel. For AED (Automated External Defibrillator) information, contact supervisor or hosting administration for details on the availability and/or location of an AED unit at your worksite.

 **ELECTROSTATIC DISCHARGE PRECAUTION**

This equipment contains electrostatic discharge (ESD) sensitive devices. ESD sensitive equipment handling methods must be used to prevent equipment damage during handling and servicing.

 **ESSENTIAL HEALTH AND SAFETY REQUIREMENT**

Refer to document “P/N 240117—Essential Health and Safety Requirements”.



**DO NOT DISCARD CONTENTS**

The product in this packaging was placed in the market after August 13, 2005. Its components must not be discarded with normal municipal or household waste.

Contact your local waste disposal agency for recovery, recycling, or disposal instructions.



## THINGS TO NEVER DO

- **NEVER** touch circuits or reach into an enclosure until the disconnection of power and absence of charge has been confirmed.
- **NEVER** service or adjust equipment alone. Electric shock can lead to cardiac arrest. Presence of immediate aid gives you a **90% chance of survival**, but this **drops by 10% with every passing minute. After 5 minutes, resuscitation without permanent heart and/or brain damage is nearly impossible.**
- **NEVER** ignore warning symbols or fail to read safety signs.
- **NEVER** skip steps in a sequence, unless specifically instructed to do so by the manual, software, and/or authorized Kratos Tech Support Personnel. Aside from risking harm to yourself, you risk doing permanent damage to the equipment
- **NEVER** touch or stand near any potentially moving parts (even if they are not in motion at the time) when the unit is in operation or powered on, as they may move without warning.
- **NEVER** stand underneath any object while it is being lifted.
- **NEVER** remove, disable, or exceed the unit's safety, software, security, or movement limits, unless specifically instructed to do so by the manual, software, and/or authorized *Kratos* Tech Support Personnel. The careless disabling of such safeguards is one of the most common causes of serious equipment damage during installation and operation.

**POWER CYCLING:** Power cycling should not be attempted without a 1 minute minimum “off” period prior to reapplication of power to allow electronics to discharge to a reasonable level. Failure to observe this rule may result in some or all electronics not re-starting correctly. Any critical use electronics subject to power loss, brown out, voltage spikes, or other undesirable input power conditions should be placed on Technical Power (refer to Kratos Document Number AE03U-A0608 for motorization and control systems and Kratos Document Number 7535794 for environmental systems and accessories). Consider placing Technical Power on an uninterruptible power system (UPS) in the event power cycling does not meet this requirement due to undesirable input power conditions.

---

## TABLE OF CONTENTS

1	Recommended Tools & Foundation Preparation .....	1
1.1	Recommended Tools .....	1
1.2	A-325 Tensioning Procedure .....	2
1.3	Foundation Preparation.....	4
1.4	9.4m Assembly & Installation Reference Drawings .....	4
2	Mount & Antenna Assembly Procedures .....	5
2.1	Assembly Sequence & Helpful Tips .....	5
2.2	General Subreflector Alignment Guidelines.....	5
3	Operation .....	6
3.1	Acquiring Satellites.....	6
3.2	Subreflector Adjustment.....	10
4	Preventive Maintenance .....	11
4.1	General Cleaning .....	11
4.1.1	Electrical Parts .....	11
4.1.2	Mechanical parts .....	11
4.2	Inspections .....	12
4.2.1	Local Control/Motor Drive Controller Inspection .....	12
4.2.2	Antenna Inspection .....	12
4.2.3	Drive System Voltage & Current Checks .....	14
4.3	Preservation & Lubrication of Component Parts.....	14
4.3.1	Preservation of Aluminum Parts.....	14
4.3.2	Preservation of Galvanized Surfaces.....	14
4.3.3	Lubrication.....	15
4.3.4	Lubrication of Jackscrews/Motors .....	15
4.3.5	Lubrication of Gear Motor/Housing Fill Drain Requirements (ES94K-1-BC) .....	16
4.3.6	Lubrication of Gear Motor/Housing Fill Drain Requirements (Non-ES94K-1-BC) .....	16
4.3.7	ES94K-1-BC Lubrication of Polarization Slew Drive Kit.....	20
4.3.8	Lubrication of Brakes .....	23
5	CORRECTIVE MAINTENANCE & TROUBLESHOOTING .....	31
5.1	Top 5 ESA Maintenance & Troubleshooting FAQ .....	31
5.2	Corrective Painting Instructions .....	31
5.2.1	Preparatory Cleaning of Aluminum Surfaces.....	31
5.2.2	Priming Cleaned Aluminum Surfaces .....	32
5.2.3	Painting Primed Aluminum Surfaces.....	32
5.2.4	Prepping & Painting Galvanized Surfaces .....	32
5.2.5	Priming & Painting Cleaned Jack Surfaces .....	32

5.3	Removing Backlash via Jack Adjustment .....	33
5.4	Maintenance Kits.....	34
6	SITE ACCEPTANCE TEST PROCEDURE.....	35
	APPENDIX: Equipment Issues & Technical Support.....	36

## LIST OF FIGURES

Figure 1-1:	Bolts Shorter than 4 Diameters .....	3
Figure 1-2:	Bolts Longer than 4 Diameters .....	3
Figure 1-3:	Scraping Foundation Pads .....	4
Figure 3-1:	Pure Noise Signal on Spectrum Analyzer .....	7
Figure 3-2:	Minimum Transponder Signal on Spectrum Analyzer .....	7
Figure 3-3:	Antenna Radiation Pattern Topographical Diagram with Plan View .....	8
Figure 3-4:	Polarization at 45 Degrees from Optimum Setting .....	9
Figure 3-5:	Maximizing Odd Transponders.....	10
Figure 3-6:	Optimum Polarization Settings .....	10
Figure 4-1:	Variable Speed Antenna Lubrication Points.....	18
Figure 4-2:	Lubrication Points for Antenna (ES94MPEXKA-1).....	19
Figure 4-3:	Polarization Slew Drive Kit Lubrication Points.....	21
Figure 4-4:	ES94K-1-BC Lubrication Points .....	22
Figure 4-5:	Azimuth Brakes.....	24
Figure 4-6:	Releasing the Brakes .....	24
Figure 4-7:	Cap-Nuts on Top of Brake Assembly .....	25
Figure 4-8:	Support Plate Screws .....	25
Figure 4-9:	Brake Disc Pack .....	26
Figure 4-10:	Tabbed Discs - Part 1.....	26
Figure 4-11:	Tabbed Discs – Part 2 .....	27
Figure 4-12:	Applying Silicone Grease .....	28
Figure 4-13:	Reinstalling Disc Pack.....	29
Figure 4-14:	Reinstalling Support Plate .....	29
Figure 5-1:	Jac/Jack Anti-Backlash Procedure.....	34

## LIST OF TABLES

Table 1-1:	Recommended Tools.....	1
Table 1-2:	9.4M Assembly & Installation Drawings/Instructions .....	4
Table 4-1:	Lubrication Chart.....	17
Table 4-2:	Lubrication Chart (ES94MPEXKA-1).....	19
Table 4-3:	Polarization Motor Lubrication Chart for Lube Points 1 & 2 .....	20
Table 4-4:	Brake Maintenance – Required & Suggested Tools and Materials.....	23
Table 5-1:	Cure Times .....	33
Table 5-2:	Maintenance Kits .....	34

# 1 RECOMMENDED TOOLS & FOUNDATION PREPARATION

The following sections offer information related to preparing to assemble/install the 9.4m ESA, such as recommended tools, foundation preparation and the details of the A-325 tensioning procedure required for the tightening of all A-325 hardware.

## 1.1 RECOMMENDED TOOLS

Kratos supplies all appropriate hardware/parts required for installation of the 9.4m ESA. All tools needed for installation, however, should be provided by the installation crew. Kratos recommends the following tools (Table 1-1) be used for installation of the 9.4m ESA:

**NOTE: The tools listed in the below table are subject to change without notice. Consult assembly instruction documents, drawings, and/or Kratos Tech Support for confirmation.**

**Table 1-1: Recommended Tools**

TOOL	SIZE	QUANTITY
<b>Open End or Combination Wrenches</b>	7/16 Inch	2
	9/16 Inch	2
	7/8 Inch	2
	3/4 Inch	2
	1/2 Inch	2
	1-1/16 Inch	2
	1-1/4 Inch	2
	1-1/2 Inch	2
	1-3/4 Inch	2
	2 Inch	2
<b>Crane</b>	15 Ton Minimum Capacity, extended end	1
<b>3/8" Diameter Nylon Choker</b>	6 Foot	1
	3 Foot	1
<b>1/2" Diameter Choker</b>	16 Foot	4
<b>Shackles</b>	5/8 Inch	4
<b>Ladders</b>	25 Foot Extension Ladder	2
	12 Foot Stepladder	2
<b>Puller Hoist</b>	1 Ton	1
<b>Hex Bit Socket</b>	1/2 Inch	1
<b>Drive Sockets</b>	7/16 Inch	2
	1/2 Inch	2
	3/4 Inch	2
	7/8 Inch	2
	1-1/16 Inch	2
	1-1/4 Inch	2
	1-1/2 Inch	2
	1-3/4 Inch	2
	2 Inch Deep, 1 Inch Drive	2
<b>Calibrated Torque Wrench</b>	250 ft-lbs	1
<b>4x Torque Multiplier</b>	1 Inch Drive	1
<b>Adjustable Wrench</b>	8 Inch	1
<b>Spud Wrench</b>	1-1/4 Inch	1
<b>Continued- Recommended Tools</b>		

TOOL	SIZE	QUANTITY
Drive Ratchets	1/2 Inch	2
	1 Inch	2
Drive Extension	1/2 Inch	2
Screwdriver	Slotted	2
Allen Wrenches	5/32 Hex Socket	1
	5/16 Inch	4
	3/16 Inch	4
	1/4 Inch	4
	5/32 Inch	4
	1/2 Inch	4
Portable Drill	Electric	1
Tape Measure (or similar measuring device)	25 Foot	1
Felt-tip Marker (or equivalent)	Standard	1
Hammer	Standard	1
Rubber Mallet	Standard	1
Pry Bar	Standard	1
Tin Snips	Standard	1
Safety Gloves (per installer)	Standard	1
Wax Stick	Standard	1 (supplied)
Tag Lines	20 Foot	4
Temporary Wood Support Lumber	2 x 4 x 8 Foot	4
Temporary Wood Support Blocks		4

## 1.2 A-325 TENSIONING PROCEDURE

Throughout the installation instructions set forth in this manual, there may be references to the A-325 hardware tensioning procedure. A-325 hardware must be properly tensioned to avoid slippage between bolted surfaces under high loads. Slippage can cause the corresponding assembly to move or slip, resulting in antenna misalignment. Use of A-325 hardware eliminates slippage between mating surfaces under high-loading conditions as well as the need for future retightening.

**NOTE: A-325 tensioning is for final connections only. Never loosen or reuse A-325 hardware.**

Points to Keep in Mind:

- “Snug tight” is defined as tightness when plies of joint are in firm contact.
- Do not proceed with felt-tip marker or tightening unless connection is final and will not be loosened again.
- If after tensioning procedure the bolts are loose, discard them and replace with new hardware.
- Do not use A-325 tensioning unless specifically called for by installation instructions.

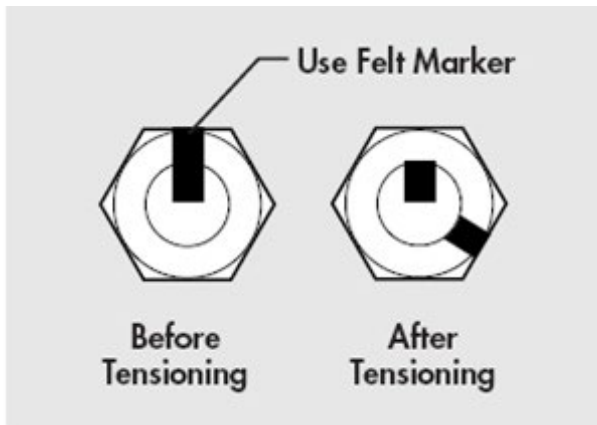

**Figure 1-1: Bolts Shorter than 4 Diameters**

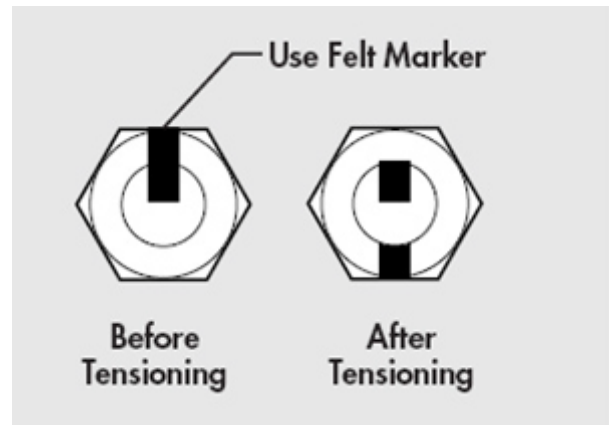

**Figure 1-2: Bolts Longer than 4 Diameters**

A-325 hardware should be tightened according to the following tensioning procedure:

1. Lubricate the bolts with provided wax stick to reduce friction.
2. Insert the bolt and add flat washer (if required). Do not allow wax to get under flat washer.
3. Add the nut, and tighten with your fingers.
4. After all connections are complete, tighten the bolts until surfaces are joined and nuts are snug (as achieved by the full effort of a single person using a standard spud wrench).
5. Using a felt-tip marker, mark the nuts and ends of the bolts with a straight line as shown above in Figure 1-1 and Figure 1-2.
6. Tighten nuts even further, using an extra-long-handled wrench, until the nuts are:

Moved 1/3 turn (120°) as shown in Figure 1-1 ("After Tensioning")

Or

Moved 1/2 turn (180°) as shown in Figure 1-2 ("After Tensioning")

**NOTE: If A-325 bolts are loosened after Steps 5 and/or 6, discard and replace with new hardware**

### 1.3 FOUNDATION PREPARATION

Before beginning the installation process on the ground mount assembly, ensure that the foundation has been prepared. Foundation specifications are provided by Kratos and may be used as a reference by civil engineering personnel when preparing the foundation for local soil conditions. These specifications are available before the shipment arrives by contacting the Customer Service Center or your Account Manager.

- Sweep foundation clear of any dirt or debris
- To ensure smooth surface for mount, scrape foundation pads as shown in Figure 1-3
- Apply stick wax to stud threads to ease later connections



**Figure 1-3: Scraping Foundation Pads**

### 1.4 9.4M ASSEMBLY & INSTALLATION REFERENCE DRAWINGS

This section provides the Kratos document numbers of all the necessary instructions, drawings, and schematics for the assembly of the 9.4m Antenna Reflector. As assembly and installation procedures are performed, be sure to refer to the appropriate documents, instructions, and/or drawings.

**NOTE: Refer to the About This Manual section for Top Level Assembly Numbers, if necessary.**

**Table 1-2: 9.4M Assembly & Installation Drawings/Instructions**

Item	ES94K-1	ES94KAA-1	ES94MPEXKA-1
Foundation Drawing	237742	7589602	7586797
Theodolite & Alignment	240379	240379	240379
Feed Rotation Drive Installation	239954	239954	239954
9.4m Enclosure Hinged Door Assembly	7587305	7587305	7587305
9.4m Enclosure Roll-Up Door Assembly	7587304	7587304	7587304
9.4m Pedestal Assembly Installation Instructions	7590290	7588858	7585152/7585990
9.4m Handwheel Installation	240377	N/A	N/A
9.4m Reflector Installation Instructions	7585328	7585328	7585328
Subreflector & Strut Installation	303272	N/A	N/A
Temporary Strut Installation	240371	N/A	N/A
Azimuth Jackscrew Assembly Instructions	N/A	N/A	N/A
Azimuth Jackscrew Assembly	N/A	N/A	N/A
Feed Thru Plate Kit Installation Instructions	240437	240437	240437
9.4m Feed Support	7585328	7585328	7585328
SRT Installation	N/A	7585115	7585115
Pattern Optimization Procedure	SP50011	SP50011	SP50011

---

## 2 MOUNT & ANTENNA ASSEMBLY PROCEDURES

This chapter provides the basic sequence and tips for the assembly of various elements of the 9.4m ESA. Appropriate drawings and schematics references for assembly of the antenna are also provided, when applicable. Refer to the drawings, instructions, and schematics for the specific system being installed, per the information provided in Table 1.2.

### 2.1 ASSEMBLY SEQUENCE & HELPFUL TIPS

Kratos recommends following these helpful tips regarding the sequence of assembly:

- Always use the correct provided hardware and use the appropriate sequence for tightening/torque, as per the instructions provided with the part or kit being assembled and/or installed (as listed in Table 1.2).
- As a rule, never fully tighten A-325 type hardware (see Section 1.2) unless instructed to do so by instructions. Once tightened, A-325 cannot be loosened. If loosened, it must be replaced with new A-325 hardware.
- The Mount should be assembled at ground level before beginning any hoisting with crane.
- The Reflector & Back Structure should be assembled at ground level before beginning any hoisting with crane.
- Theodolite Alignment should be performed at ground level before beginning any hoisting with crane.
- During assembly of the Azimuth Jackscrew, ensure that the Azimuth Jackscrew assembly is in the fully retracted position.
- During hoisting (with crane) of the Motor/Jack Assembly, do NOT attach any ropes to the Small Motor.
- Always attach hoisting ropes in such a way that moving parts will not drop/rotate when lifted.
- Realignment of the Panning Frame/Pivot Assembly may be necessary to ensure proper alignment of the Azimuth Jackscrew pin. Make snug the Panning Frame/Pivot Assembly hardware and fully extend the Azimuth Jackscrew so that binding does not occur along the full range of the Azimuth Pivot.

The following steps represent the recommended (but not required) basic sequence of assembly for this antenna:

**NOTE: More steps may be required, in addition to those listed below, depending on the antenna type and/or the presence of particular options. Refer to Table 1.2 to locate document numbers for the system being installed. Such documents will be provided in the shipment of each part, kit, and/or option.**

- Pedestal Assembly
- Reflector & Back Structure Assembly
- Theodolite & Alignment
- Feed Rotation Drive Installation
- Subreflector Assembly & Installation

### 2.2 GENERAL SUBREFLECTOR ALIGNMENT GUIDELINES

The primary goal of Subreflector alignment is for the Subreflector to be properly centered and for the height to be adjusted to the correct focal length for the antenna.

Keep the following guidelines in mind during Subreflector alignment:



- A tape measure is generally used in order to center the Subreflector
- Measure from a repeatable location, running the tape measure from the 4 locations where the strut ends meet the main reflector to the inside edge of the Subreflector
- For centering measurements, a zero delta between all is ideal
- Focal length is measured from the antenna vertex to the edge of the Subreflector at the three Adjustment Rod locations on the Subreflector
- Target focal length distance is determined by antenna type
- Normally, the process of centering the Subreflector then the Subreflector height is repeated until both centering and height are “nuts on” precise

### 3 OPERATION

After completing the assembly of the antenna, the 9.4m ESA is ready to become operational. To operate the 9.4m ESA, it is necessary to direct it to the desired satellite and adjust both Elevation and Azimuth angles appropriately. These procedures provide details on how to correctly position the antenna on a desired satellite.

**NOTE: If intending to use a Kratos NGC Indoor Unit (NGC-IDU) or NGC Outdoor Unit (NGC-ODU) in order to control antenna, it is best to refer to the appropriate manuals of the NGC Documentation Package received with that unit.**

#### 3.1 ACQUIRING SATELLITES

There are a number of possible procedures for acquiring a satellite. Kratos recommends that a Spectrum Analyzer of some type be used, regardless of your chosen procedure.

While viewing any Spectrum Analyzer screen, a pure noise signal will likely be observed, as shown below in Figure 3-1. Additionally, some transponder signals may be observed above the noise signal, as shown below in Figure 3-2.

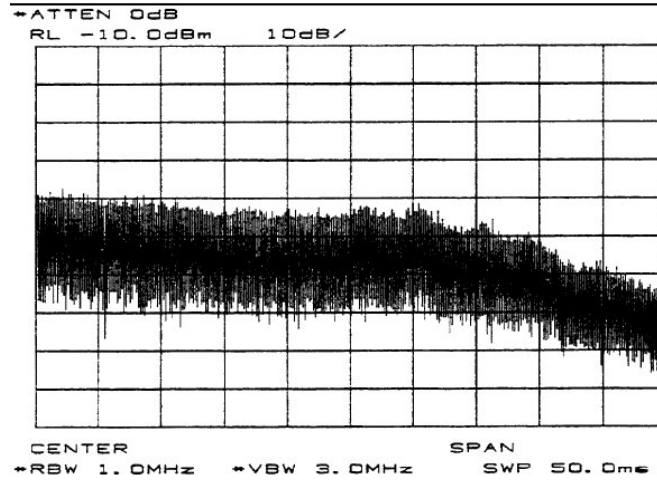

**Figure 3-1: Pure Noise Signal on Spectrum Analyzer**

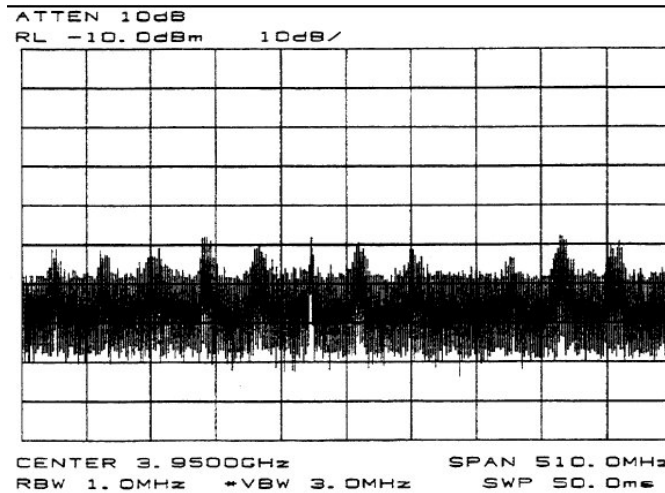

**Figure 3-2: Minimum Transponder Signal on Spectrum Analyzer**

Use the following steps in order to acquire a satellite:

Step 1 of 9: Manually move the antenna in the Azimuth direction (scanning back-and-forth) to achieve a maximum transponder signal with the greatest amplitude

- Scan in one direction until amplitude continues to diminish, and then scan in opposite direction until the same occurs
- Return to the position yielding the greatest amplitude
- The maximum Azimuth excursion from the original setting should not exceed +/- 1.5 Degrees, or the antenna may begin to access a different satellite than the one desired.

Step 2 of 9: With the antenna positioned in Azimuth, with the transponder signal maximized, follow the same procedure as in Step 1, only this time using the Elevation direction (scanning up-and-down). Once again, do this until the transponder signal has been maximized.

Step 3 of 9: Repeat this procedure, alternating between the Azimuth and Elevation excursions of the antenna, until you have peaked the antenna transponder amplitude.

- Transponder signal amplitude of 30 dB or greater from peak to average noise signal indicates that the antenna is receiving the signal on the main beam.
- Transponder signal amplitude of less than 30 dB indicates the antenna is peaking on a side lobe of the main beam.

Step 4 of 9: If the antenna is peaked on a side lobe in Az or El, move the antenna Azimuth while observing the Spectrum Analyzer screen, as illustrated below in Figure 3-3.

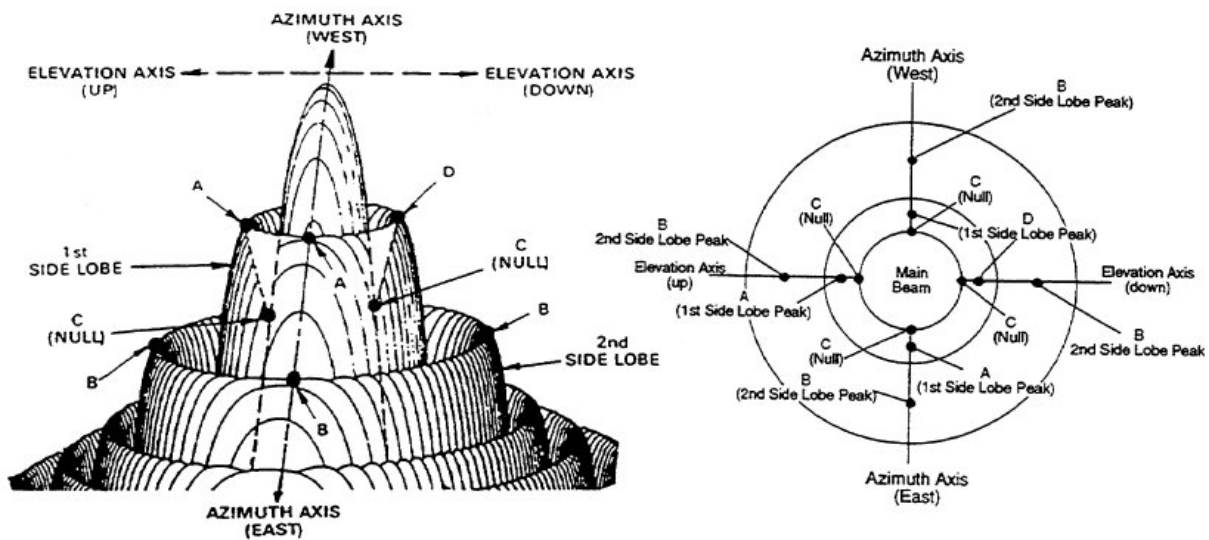

Figure 3-3: Antenna Radiation Pattern Topographical Diagram with Plan View

Step 5 of 9: If the signal amplitude diminishes and does not increase (position B) to the level that was noted when the antenna was peaked on a side lobe, then this means that the antenna is moving away from the main beam. Reverse the direction of antenna movement.

- From the original side lobe position (Position A), the signal amplitude should now diminish to a null point at Position C (minimum amplitude showing only signal noise) and then symmetrically increase again to the same level at Position D as noted at Position A
- At the null point (Position C), the antenna is aligned with the alternate (EI) axis. If antenna was peaked on a side lobe in Azimuth, it was appropriately aligned with the EI axis (go to Step 6).
- If the antenna was peaked on a side lobe in Elevation, it was appropriately aligned with the Az axis (go to Step 6, moving the antenna in Azimuth rather than Elevation).

Step 6 of 9: Move the antenna in Elevation while observing the Spectrum Analyzer screen. If the signal amplitude increases, then decreases, and then increases again (but to a lesser value than the first increase), this means the antenna is moving in the wrong direction. Reverse direction of antenna movement.

- From the original null point, the signal level should increase and decrease alternately, but with increasing amplitude until the transponder signal increases to a level of at least 30 dB, at which time it will be on the main beam. Continue to manually peak the signal to a maximum level, using Azimuth and Elevation adjustments.

Step 7 of 9: If antenna is aligned in Azimuth and Elevation (signal maximized) and a total of 24 transponder signals of relatively equal amplitude are NOT noted (12 horizontal + 12 vertical = 24), the Polarization adjustment is set incorrectly and must be modified. If 12 transponder signals are noted, they may or may not be the properly polarized signals. Therefore, 24 transponder signals must be visually noted in order to determine the proper Polarization setting.

Step 8 of 9: Rotate the feed assembly clockwise until 24 transponder signals are noted and of approximately equal amplitude.

**NOTE: It is more accurate and visually simple to minimize alternate set of transponder signals rather than maximizing the transponder of interest.**

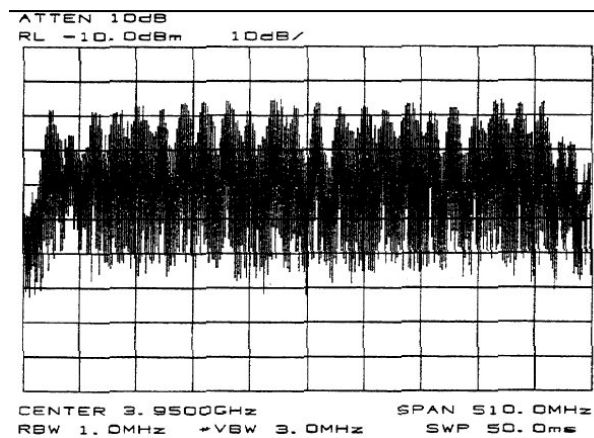

**Figure 3-4: Polarization at 45 Degrees from Optimum Setting**

Step 9 of 9: With all 24 transponder signals of approximately equal amplitude appearing on the Spectrum Analyzer screen, determine the specific antenna system and satellite parameters. Rotate the feed assembly as required until the appropriate (odd or even) transponder signals have been maximized.

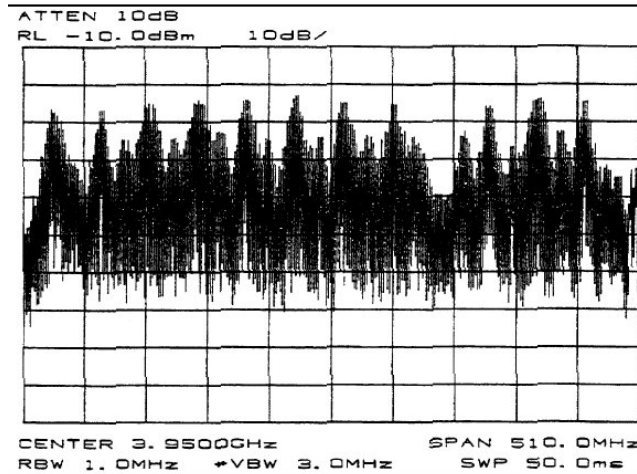

Figure 3-5: Maximizing Odd Transponders

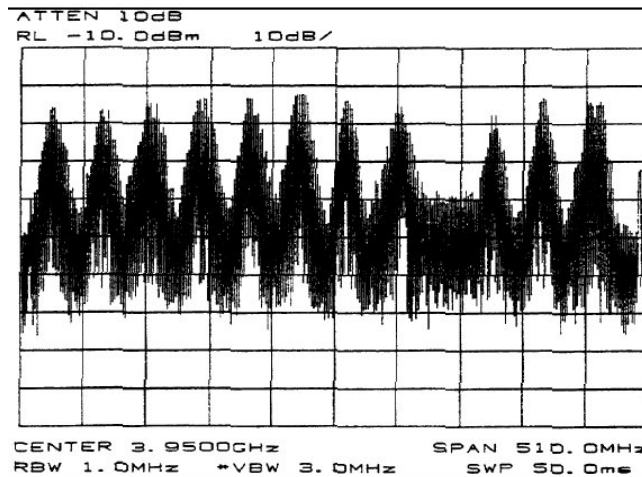

Figure 3-6: Optimum Polarization Settings

### 3.2 SUBREFLECTOR ADJUSTMENT

Refer to *Kratos Special Publication (Document # SP50011)*.

## 4 PREVENTIVE MAINTENANCE

This chapter contains periodic preventative maintenance instructions for the 9.4m Earth Station Antenna. Included are instructions for performing inspections, preventative maintenance procedures, and cleaning.

**NOTE: Refer to applicable vendor manuals for any repair procedures that are not included in this manual.**

Regularly replacing normally functioning assemblies or components as a preventative measure is not required. Malfunctions of this ESA can normally be traced to components and/or parts through the use of troubleshooting procedures.

### 4.1 GENERAL CLEANING

To prevent excessive accumulation of dust and dirt, as well as to ensure the removal of various contaminants, the equipment needs to be thoroughly cleaned. It is recommended that you clean the antenna every time you conduct a visual inspection of the components. No special cleaning procedures are required. However, to ensure trouble-free operation, you will need to clean in accordance with procedures in Sections 4.1.1 & 4.1.2.

#### 4.1.1 ELECTRICAL PARTS

**CAUTION: CONFIRM ALL ELECTRICAL POWER IS REMOVED BEFORE PROCEEDING.**

Minor cleaning, such as the removal of dust and loose foreign particles, can be accomplished by one or all of the following methods:

- Vacuuming
- Using a soft-bristle brush or lint-free cloth
- Using an air compressor, with dry air at a LOW PRESSURE (between 5 and 25 psi), to blow out dust and dirt

**NOTE: When using air to clear contaminants, take extreme care when blowing air stream on or near ANY delicate parts.**

To remove imbedded dirt, grease, and/or oil from electrical parts:

- Use a 50% solution of Isopropyl "rubbing" alcohol
- Apply to surface with a soft-bristle brush

**NOTE: At times, it may be necessary to brush some parts vigorously with a stiff bristle brush in order to remove imbedded or hardened dirt particles.**

**NOTE: After cleaning, ALLOW CLEANED PARTS TO DRY FOR 10-15 MINUTES before restoring power and/or returning equipment to operation.**

#### 4.1.2 MECHANICAL PARTS

Cleaning of mechanical parts begins by removing dust, dirt, and other loose contaminants with a scraper, stiff-bristle brush (or wire brush in cases of rust or corrosion removal), lint-free cloth, or compressed air

---

(pressure between 25 and 40 psi). Any accumulation of imbedded dirt, corrosion, grease, or oil deposits which require more cleaning may be removed with a stiff-bristle or wire brush, along with a cleaning solvent such as acetone (or equivalent).

**NOTE: After cleaning, ALLOW CLEANED PARTS TO DRY FOR 10-15 MINUTES before restoring power and/or returning equipment to operation.**

## 4.2 INSPECTIONS

The frequency of inspection is contingent upon the user's individual standards and the operational environment in which the earth station antenna is located. However, a visual inspection of the components should be performed at least semi-annually. Where there are no established wear limits, perform a visual inspection to locate worn or damaged parts that could result in a malfunction of the earth station antenna. It is recommended that the mechanical and electrical inspections be performed on the assembled or partially disassembled equipment to determine the extent of disassembly required prior to completely disassembling a component or module that is suspected of malfunctioning.

In the absence of any special inspection requirements, operational tests are the most effective means in isolating parts and assemblies requiring further inspection. During inspection, any noted damage and/or problematic condition which could preclude the continuation of proper operation (prior to the next scheduled inspection) should be recorded. These discrepancies should be immediately corrected (either by repair or replacement, as required), or dealt with immediately after the inspection procedure has been completed.

**CAUTION: ALLOWING THE ANTENNA TO CONTINUE TO OPERATE AFTER DAMAGE OR DISCREPANCIES HAVE BEEN NOTED DURING INSPECTION MAY RESULT IN PROPERTY DAMAGE (ESPECIALLY TO YOUR EARTH STATION ANTENNA), AS WELL AS INCREASE THE RISK OF CREATING DANGEROUS SITUATIONS FOR PERSONNEL, CAUSING PERSONAL INJURY AND/OR LOSS OF LIFE.**

### 4.2.1 LOCAL CONTROL/MOTOR DRIVE CONTROLLER INSPECTION

For details on inspections for the Local Control/Motor Drive Controller, refer to the appropriate antenna control documentation.

### 4.2.2 ANTENNA INSPECTION

Inspection of the antenna generally conforms to standard visual inspection procedures performed on electromechanical equipment. In addition to these procedures, perform the following checks and visual inspections for the specific conditions as noted:

- Inspect all wiring and cables, particularly the network-to-enclosure and enclosure-to-mount interfaces, for discolored and/or burned insulation, entry of water/moisture, corrosion, dirt, breaks, secure connections, and any other signs of damage or deterioration. Examine connections for dirt, corrosion, and mechanical defects. Check for loose or broken lacing, as well as cuts, braiding, dry rot, or cracks in insulation.
- Inspect all connectors for corrosion, broken inserts, and stripped threads. Inspect connector shells, checking for distortion and dents. Inspect contact pins for bends, misalignment, and/or other deformities. Check connector inserts for carbon tracking, burns, or charring, indicating arc-over.

- Check all electrical components for dirt, cracks, chips, breaks, discoloration, and any other signs of damage or deterioration. Discoloration, blistering, or burns are evidence of overload(s). Measure the actual value(s) of any suspect electrical components (as with a digital multimeter) and compare against value(s) in the product's specifications.
- Operate the Azimuth and Elevation drives, as well as the feed rotation (if applicable) in both the plus and minus direction from the local control/motor drive controller at least once every three (3) months during antenna down time. Check to make sure the mechanical Hard Limit switches stop the antenna and feed movement, and limit travel to prevent structural interference and damage. Check the mechanical Hard Limit switches for corrosion and water entry. Check the arm on the feed limit switch for free movement, with no binding or interference. Be certain both of the feed rotation limit switch arms are not distorted and ride centrally on the actuating cam to open their corresponding Hard Limit switch.
- Inspect the Azimuth and Elevation Jackscrew boots for security of attachment at both ends, checking for abrasions, tears, cuts, dry rot, and other damage that might expose the jackscrew to environmental conditions (rain/water/ice, dust, etc.). Minor repairs can be made by resealing compromised areas with RTV-108 silicone rubber sealant.
- Visually inspect the feed window for dirt. Check the feed, feed supports, feed window, and reflector for distortion, foreign object damage, and environmental deterioration (due to snow/ice, rain, hail, high winds, etc.). Environmental deterioration can result in damage and/or deformation of both the electrical components and the structure.
- Check the cable attachment to the resolvers, to the LNA/LNB, and the enclosure-to-mount interface for security. Check the cable routing for secure hanger attachment. Check cable insulation for cuts, cracks, abrasions, and other signs of damage or deterioration. Check LNA/LNB and resolvers for secure mechanical attachments. Ensure there is proper torque in setscrews of Polarization drive gear box, and proper tensioning of corresponding drive chain assembly (if applicable).
- IF APPLICABLE, check that drain holes in bottom of the enclosure and pedestal are not obstructed, and there is no evidence of water accumulation. Check enclosure doors for proper closure. Verify door seals are intact and free of tears, abrasions, and/or other damage. Check that all other seals are intact, and repair with coating of RTV-108 silicone rubber sealant as needed to seal exposed electrical fittings, bolt holes, and/or any other points of possible water entry to electrical components to maintain a waterproof condition. If enclosure has a vent fan, inspect fan blade for freedom of operation. Fan bearings are permanently lubricated. However, any binding, abnormal noises, and/or vibration means replacement of the fan assembly is needed. Check fan filter element and if dirty or obstructed with dust, replace it.
- Visually inspect all mechanical parts for freedom of operation with no misalignment, binding, or interference. Check all cabling for sufficient slack in order to prevent cable strain while still providing enough restraint to adequately prevent abrasions and/or chaffing during antenna and feed movement.
- Check antenna mounting and interconnecting assembly hardware for security. Verify that all electrical grounding connections (including cross-axis grounding straps) are intact and secure, free of corrosion or breaks. Use a wire brush to thoroughly clean any noticeably corroded portions of grounding cables, the un-plated portion of universal terminals, and corresponding mounting surfaces. Any loose A-325 Hardware **MUST BE REPLACED** rather than tightened. A-325 hardware distorts at initial installation and, once loosened, will not maintain the required high strength friction



connection. All other (not A-325) assembly and installation hardware should be tightened to its original torqued condition. When installing new structural hardware, do not use a wrench with a lever arm longer than two (2) feet.

- Examine all painted aluminum or galvanized surfaces for chips, cracks, or deep gouges, and touch-up spots as needed.
- In order to maintain reliable azimuth axis drive system performance, the azimuth axis brake assemblies should be inspected and maintained at an interval of no less than 6 months and more frequently in severe conditions (high humidity, airborne salt vapor, and other environments containing heavy airborne contaminants). Since the brakes are always released (pulled in) in normal operation, the brakes sit in a stationary position for long periods of time. Exercising the brakes by activating and clearing an E-Stop condition 5-10 times during regular maintenance intervals is the best way to ensure long-term reliability.

### 4.2.3 DRIVE SYSTEM VOLTAGE & CURRENT CHECKS

For details on Drive System Voltage and Current Checks, refer to the appropriate antenna control documentation.

## 4.3 PRESERVATION & LUBRICATION OF COMPONENT PARTS

### 4.3.1 PRESERVATION OF ALUMINUM PARTS

Remove all loose paint and corrosion by scraping, wire brushing, or using steel wool. If using steel wool near the feed window, make sure that none remains on the feed horn window. Edges of existing paint can be blended with the metal surface using fine grit sandpaper. Wipe the surface to be painted with a soft rag dampened with a small amount of acetone or equal. Be certain to remove all loose paint, corrosion, imbedded dirt, grease, and oil deposits or the paint will not adhere to the surface. Acetone will dissolve paint if applied heavily and rubbed vigorously. The reflector may be washed with plain water, if necessary. Do not use bleach, soap solutions, or kerosene as it is difficult to remove the residue. Allow the cleaned surface to dry thoroughly before priming.

Prime the cleaned surface by applying zinc chromate primer. The primer can be applied with a brush, roller, or pressurized spray. If necessary, thin the primer with acetone to the proper consistency. Feather the primer onto the adjacent painted surfaces. Allow primer to thoroughly dry before applying the finish paint coat.

Paint all RF surfaces, such as the inside of the main reflector and subreflector with highly-reflective white paint. This type of paint disperses light rays, reducing the focusing effect of the sun's radiation, thereby reducing heat build-up caused by the focused sunrays on the feed system. Rear surfaces of the reflector and subreflector may be painted with flat-white enamel paint. The paint can be applied with a brush, roller, or pressurized spray. If necessary, thin the paint with the appropriate thinner to the proper consistency. Thoroughly paint over the primed surfaces and blend with the existing painted surface.

### 4.3.2 PRESERVATION OF GALVANIZED SURFACES

Remove all loose paint and corrosion by scraping, wire brushing, or using steel wool. Edges of existing paint can be blended with the metal surface using fine grit sandpaper. Wipe the surface to be painted with a soft rag dampened with a small amount of acetone, or equal. Be certain to remove all loose paint, corrosion, imbedded dirt, grease, and oil deposits or the paint will not adhere to the surface. Acetone will

dissolve paint if applied heavily and rubbed vigorously. Do not use bleach, soap solutions, or kerosene as it is difficult to remove the residue. Allow the clean surface to dry thoroughly before painting.

Paint the cleaned surface with a zinc-rich paint. The paint can be applied with a brush, roller, or pressurized spray. If necessary, thin the paint with the appropriate thinner to the proper consistency. Thoroughly paint over the cleaned surface and blend with the existing painted surface.

### 4.3.3 LUBRICATION

For long life and trouble-free operation, be certain not to extend the lubrication schedule beyond the frequency recommended in the Lubrication Chart. The frequency should be shortened if the antenna is subjected to an adverse environment (e.g., high temperature, extended periods of rainfall, high humidity, dust storms, etc.). Any component or part should immediately be lubricated if during inspection or operation rough, jarring, or intermittent motion is noted, or if squeaky or other unusual noises are heard. Lubrication is required on all metal-to-metal rolling or sliding parts. Use the lubricants recommended. Do not over lubricate. Over lubrication can often be as damaging as under lubrication. Prior to the application of lubricant to any parts, use a clean cloth and/or bristle brush and remove any old lubricant to prevent an excessive build-up. Be certain to remove any protective caps and clean each lubricated fitting prior to injecting fresh grease. The Elevation and Azimuth Jackscrew Assemblies are equipped with a grease fitting and corresponding pipe plug on opposite sides of the jack housing. Remove the appropriate pipe plug and fill with grease until lubricant seeps from the pipe plug opening. Replace and securely tighten pipe plug.

The following is a list of the lubricant characteristics:

- Lubrication Engineers (LE) 4622: LE4622 is Lithium complex grease. Operating temperature range is -40 degrees to 400+ degrees Fahrenheit (-40 degrees to 204+ degrees Celsius).
- Mobil SHC32: low temperature clay thickener. Operating temperature -50C to 180C (-58F to 356F)
- Mobil SHC/100/220/624: low temperature synthetic oil. Operating temperature range is -40 degrees to 356 degrees Fahrenheit (-40 degrees to 180 degrees Celsius).
- Moly Grease: grease lubricant containing molybdenum disulfide. Operating temperature range is -85 degrees to 300+ degrees Fahrenheit (-29 degrees to 149+ degrees Celsius).
- Mobilgrease 28 wide temperature clay thickener grease. Operating temperature from -54C to +177C (-65F to 350F)

### 4.3.4 LUBRICATION OF JACKSCREWS/MOTORS

Periodically inspect lifting screws on jackscrew ballscrew assemblies to ensure adequate lubrication. Loosen Jackscrew ballscrew boot clamps to expose the lifting screw assembly. Fully extend jackscrew assembly being careful not to exceed preset mechanical limits. Brush thin coating of SHC32 grease on exposed lifting screw. Replace boot and attach corresponding boot clamps. If lifting screw is rusty, remove existing lubricant with solvent and wire brush rusted area. Rinse with solvent and apply fresh grease.

Periodically inspect and remove dust or dirt deposits from the motor housings to avoid hindering the heat exchange with the ambient air. Slight dirt accumulation on the air vent screw through splash oil cannot be avoided; however, keep vent screw clean to ensure proper pressure compensation.

#### 4.3.5 LUBRICATION OF GEAR MOTOR/HOUSING FILL DRAIN REQUIREMENTS (ES94K-1-BC)

The gearmotors implemented on the ES94K-1-BC Antenna contain synthetic lubrication. Synthetic lubrication combined with the intermittent duty use of the earth station antenna provides for maintenance free operation over the life of the gearmotor.

ES94K-1-BC Antenna  
Motor Kit: NGC-MK94  
Az Motor: AE03J-A2112  
EI Motor: AE03J-A2111

#### 4.3.6 LUBRICATION OF GEAR MOTOR/HOUSING FILL DRAIN REQUIREMENTS (NON-ES94K-1-BC)

Lube points 2, as shown in the Lubrication Chart (Table 4-1), may require removal of the indicated drain plugs and, by using a measuring cup, collection and measurement of the amount of oil that drains out. The specified amount of oil must be added to the gear motor/housing (after the drain plug has been reinstalled), using a supplied funnel to pour new oil into the fill/vent plug opening. The addition of oil requires the use of an appropriate filling utensil. Use of a modified level stick will NOT correctly gauge the appropriate amount of oil that is present in the gear housings.

**NOTE: Refer to Figure 4-1 for illustrations of the lubrication points detailed below in Table 4-1.**

**Table 4-1: Lubrication Chart**

LUBE PT. #	COMPONENTS TO BE LUBRICATED	FREQUENCY (MONTHS)				TYPE OF SERVICE	LUBE TYPE	#/QTY OF LUBE POINTS
		1	3	6	12			
1	Az/EI Jackscrew			X		Brush	SHC32/ Mobilgrease 28	1
2	Az/EI Jackscrew Gear Housing Fill & Drain		I*	C**/**		Pressure Fitting	LE4622	10 oz
3	Pol Drive Gear			X		Brush	LE4622	Minimum Surface Coverage
4	Feed Rotation Worm Gear Pillow Blocks			X		Pressure Fitting	LE4622	2
5	EI Axis Pivot Points			X		Pressure Fitting	SHC100	2
6	Az Bearing			X		Pressure Fitting	LE4622	2
7	EI Jack Clevis, Azimuth Adjust (manual)			X		Pressure Fitting	SHC100	1
8	Sub Reflector SRT 3 axis (if applicable)			X		Pressure Fitting	LE4622	8

X = Lubricate      I = Inspect    C = Change

\* Inspection requires checking for visible signs of leakage. Drain, replace, and add oil to ensure appropriate level requirements. Excessively dirty oil requires replacement with fresh oil. In case of excessive oil leakage, refer to appropriate troubleshooting info. Periodic inspections can be less frequent after the second scheduled inspection is completed without problems.

\*\* Initial oil change requirements include flushing gear boxes with a standard cleaning agent.

\*\*\* For motors that have no visible drain or fill plugs no maintenance is required, and just a general inspection for oil leakage is needed

Type 'HS' & 'STHS' drives only: 10 oz required for Gearbox on type 'MS' drives

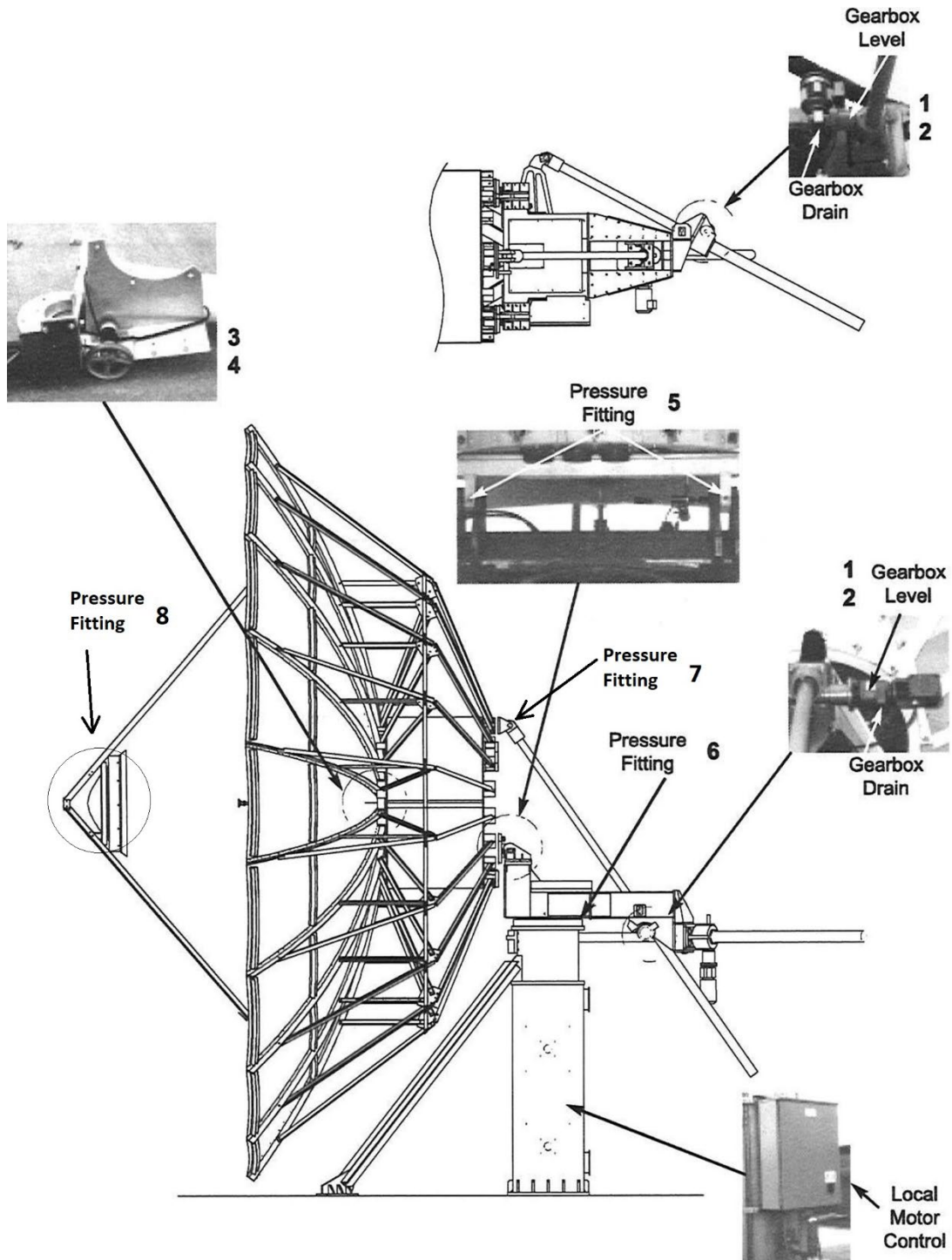

**Figure 4-1: Variable Speed Antenna Lubrication Points**

Refer to Figure 4-2 for illustrations of the lubrication points detailed below in Table 4-2.

**Table 4-2: Lubrication Chart (ES94MPEXKA-1)**

Lube Point #	Components to be Lubricated	Frequency (Months)			Type of Service	Lube Type	#/Qty of Lube Points
		6	12	24			
1	El Jackscrew Housing	x			Pressure Fitting	SHC220	1
	El Jackscrew Gear Housing		x		Pipe Plugs	SHC 624	10 oz
2	Az Gear Reducer			x	Oil Drain/Fill	SHC 624	16.2 liters Each drive
3	Pol Drive Gear (if applicable)	x			Brush	Moly Grease	Min. Surface Coverage
4	Feed Rotation Worm Gear Pillow Blocks (if applicable)	x			Pressure Fitting	SHC100	2
5	El Axis Pivot Points	x			Pressure Fitting	SHC100	2
6	Azimuth Bearing Gear and Pinion Gear Tooth Mesh	x			Brush	SHC100	Surface
7	Azimuth Bearing	x			Pressure Fitting	SHC220	2

x = Lubricate

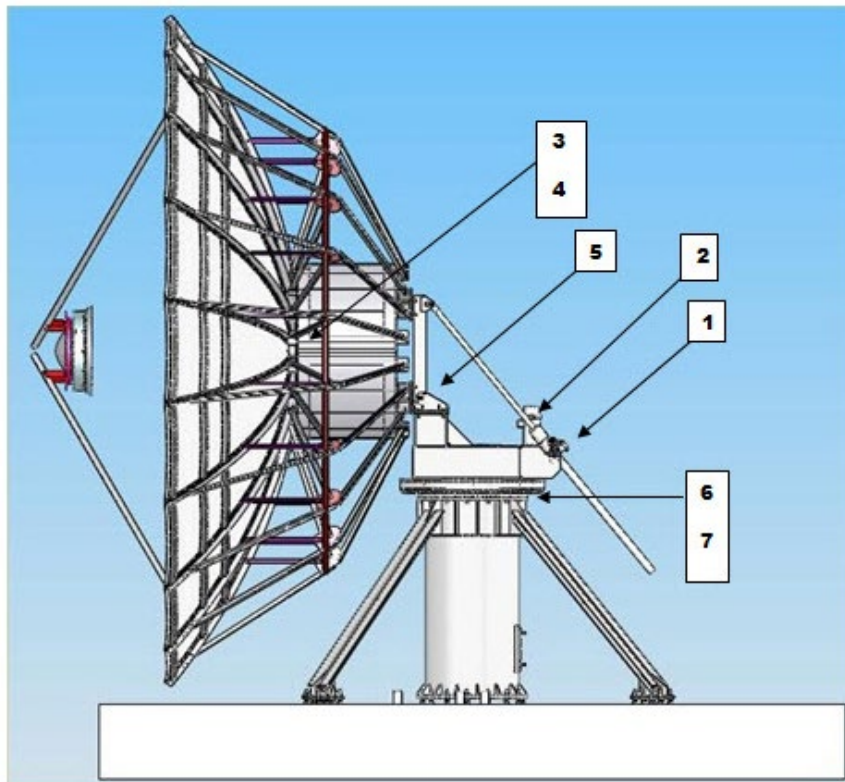

**Figure 4-2: Lubrication Points for Antenna (ES94MPEXKA-1)**

### 4.3.7 ES94K-1-BC LUBRICATION OF POLARIZATION SLEW DRIVE KIT

The slew drive on the ES94K-1-BC requires adequate lubrication (7593550 Lube Kit). The upper manifold (Lube Point 1) provides maintenance access to apply grease into the tapered roller bearings and the worm thread. The lower manifold (Lube Point 2) provides maintenance access to apply grease into the inner slew bearings. See Table 4-3 and Figure 4-3.

- Lubrication Type: Mobile Centaur XHP 462

**Table 4-3: Polarization Motor Lubrication Chart for Lube Points 1 & 2**

ENVIRONMENT*	PRODUCT TYPE		
	W/S	WE/SE	WEA/SEA
Dry and clean conditions	Every 500 hours of operation or once a year	Every 500 hours of operation or once a year	Once a year
Difficult conditions	Every 30 hours of operation or once every 3 months	Every 50 hours of operation or once every 6 months	Every 300 hours of operation or once every 6 months
Aggressive climatic conditions/more than 70 continuous operating hours per week	Every 25 hours of operation or once every 2.5 months	Every 40 hours of operation or once every 3 months	Every 150 hours of operation or once every 4 months
Extreme conditions	Every 20 hours of operation or once every 2 months	Every 30 hours of operation or once every 3 months	Every 50 hours of operation or once every 3 months

\*Note: Operating Conditions:

- Environmental operating temperatures of -30 deg C to +60 deg C
- Drive rotational output speed <2 rpm
- Low to medium drive output torques per the following table:

Size	7"	9"	12"	14"	17"	21"	25"
Output torque (kN-m)	.75	3.25	3.75	4	5	7.5	9
Output torque (ft.lb)	553	2397	2766	2950	3700	5500	6650

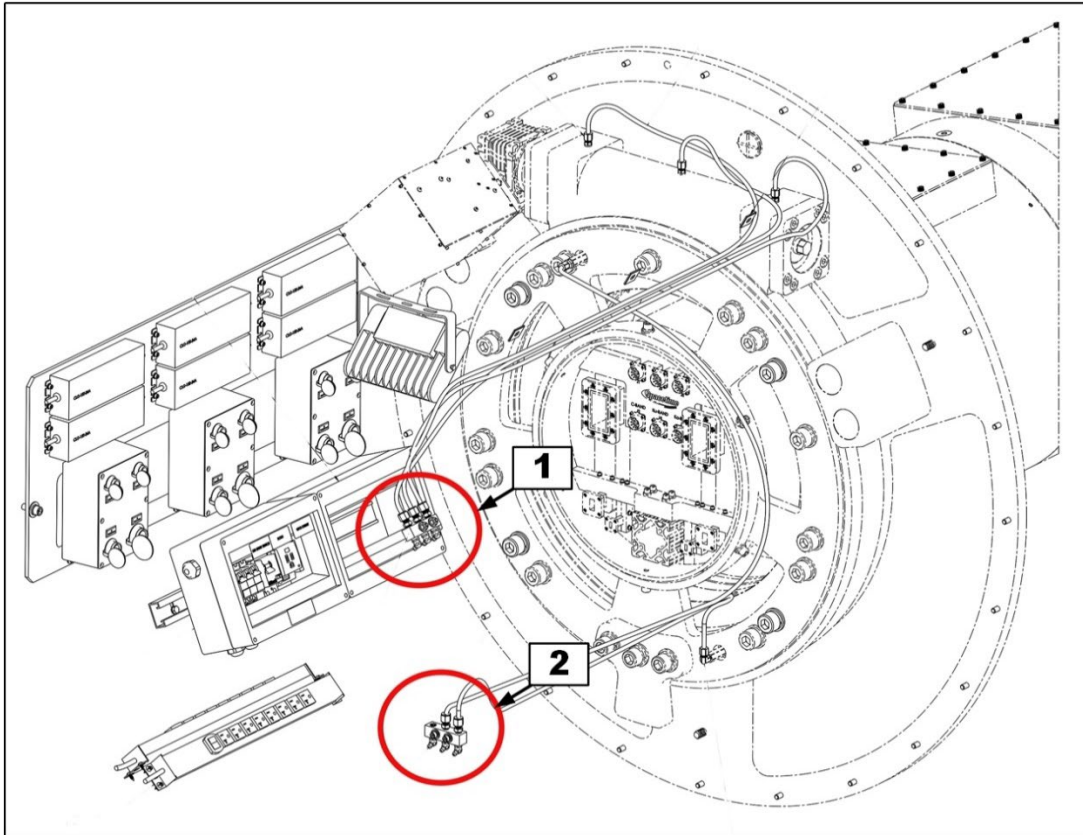

**Figure 4-3: Polarization Slew Drive Kit Lubrication Points**



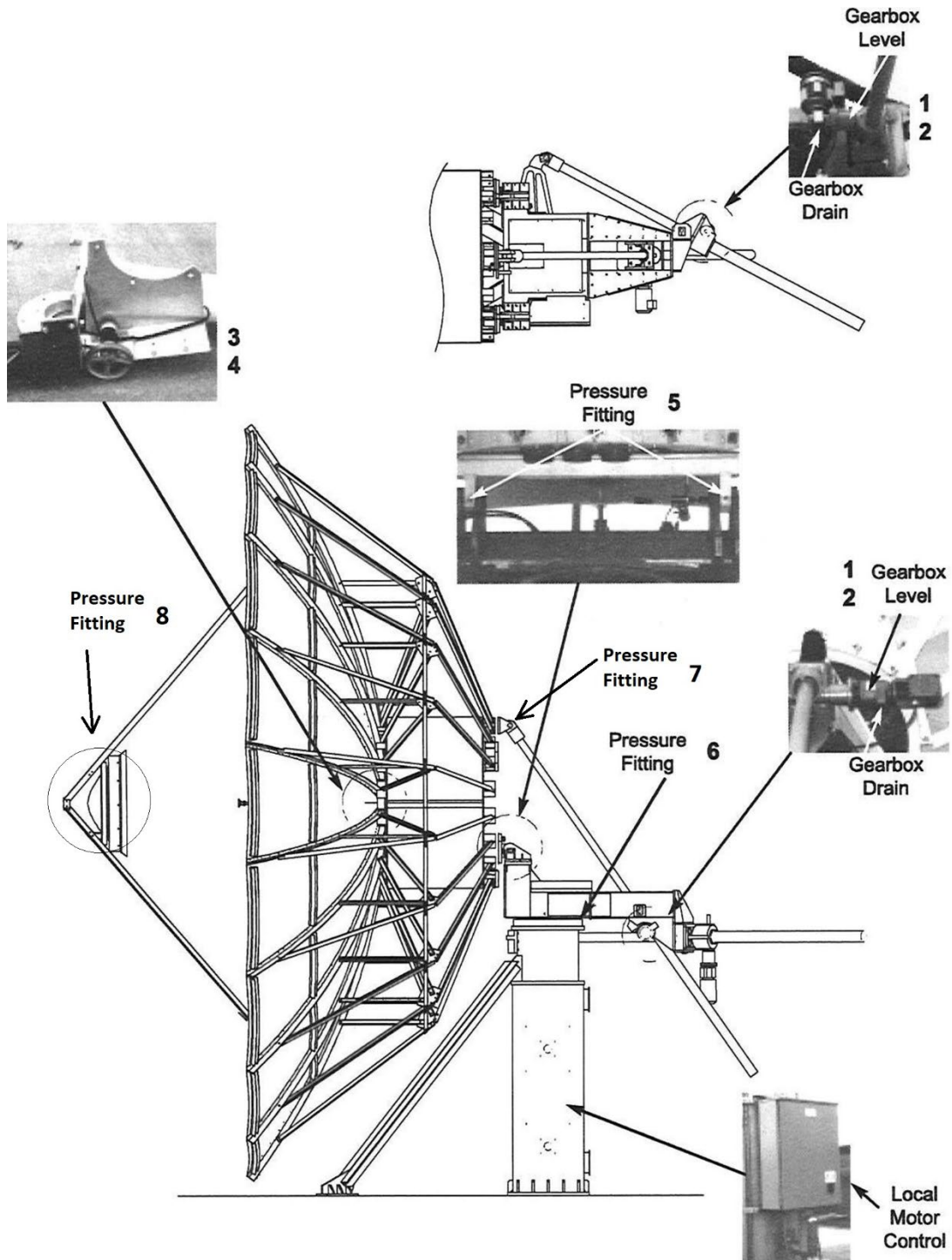

Figure 4-4: ES94K-1-BC Lubrication Points

#### 4.3.8 LUBRICATION OF BRAKES

In order to maintain reliable azimuth axis drive system performance, the azimuth axis brake assemblies should be inspected and maintained at an interval of no less than 6 months and more frequently in severe conditions (high humidity, airborne salt vapor, and other environments containing heavy airborne contaminants). Refer to Table 4-4. Since the brakes are always released (pulled in) in normal operation, the brakes sit in a stationary position for long periods of time. Exercising the brakes by activating and clearing an E-Stop condition 5-10 times during regular maintenance intervals is the best way to ensure long-term reliability.

**Table 4-4: Brake Maintenance – Required & Suggested Tools and Materials**

Item	Description
(Required) Silicone Faucet Grease (PartsMasterPro P/N 58352B)  Or  Silicone Grease (DANCO P/N 88693)	Used to protect cleaned areas of the brake sliding tabs from moisture leading to corrosion.
(Required) Penetrating Catalyst (Blaster Model P/N PB-TS-B)	Used to clean parts where rust is removed and provide rust and corrosion protection.
(Required) Clean dry shop towels	
(Required) 3/8" or 1/2" Flathead Screwdriver	Used for removing the brake cover and support plate.
(Suggested) Wood-Handled "Chip" Brush (or equivalent) (Home Depot P/N 1500-1)	Used to aid in rust removal.
(Suggested) Emory Cloth (or equivalent) (180 Grit)	Used to aid in rust removal.
(Suggested) "Acid" Brush (or equivalent) (Home Depot P/N 307122)	Used to aid in applying Silicon Grease.
(Suggested) Compressed or Forced Air	Used for removing rust and sanding residue.

**Note: The location of the azimuth brake/gearmotor may vary.**

1. Obtain clearance from the Antenna Operations Center that the antenna is out of service and ready for pedestal azimuth axis brake inspection and maintenance.
2. Locate the azimuth brakes on the ends of the azimuth axis gearmotors and stage materials and tools appropriately to perform the necessary maintenance. Remove the rear cover on the 9.4M antenna motor housing to access the azimuth brakes. See Figure 4-5.



**Figure 4-5: Azimuth Brakes**

3. Open the Outdoor Unit (ODU) and turn OFF the “Logic Power” circuit breaker, which completely removes all electrical power from the azimuth brakes and shuts down the ODU logic system for safety purposes.
4. As you progress through this procedure, pay careful attention to the orientation of all parts as you go, so that you can restore the parts to the same general state afterwards. Also, take before and after photos to support the maintenance report to be provided at the completion of this maintenance procedure.
5. Only release one brake at a time so that the antenna is held in place by the brake not under inspection and maintenance. Place the manual brake lever in the DOWN position on the gearmotor that you will be working on and in the UP position on the gearmotor that will be holding the antenna in place. You can now test whether you can move the square end of the motor shaft on top of this gearmotor with your hand. The motor shaft should turn freely with only gearing resistance present (i.e., more resistance in the direction the gearing winds up and less in the direction the gearing unwinds). Alternately, with the lever UP, the brake should engage and the square end of the motor shaft should not be able to be rotated. See Figure 4-6.

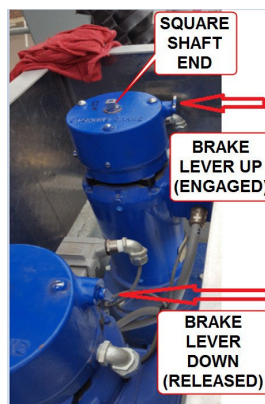

**Figure 4-6: Releasing the Brakes**

6. Remove the 3 cap-nuts on top of the brake assembly housing with a flat head screwdriver. See Figure 4-7: Cap-Nuts on Top of Brake Assembly Figure 4-7. **CAUTION: Do not lose the rubber sealing washers on each as they must be re-used on reinstallation of the cap-nuts.**

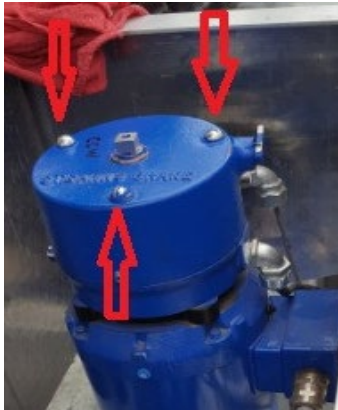

**Figure 4-7: Cap-Nuts on Top of Brake Assembly**

7. Remove the upper brake cover housing being careful not to damage the motor shaft seal in this housing. A rubber mallet (or equivalent) may be required to free the cover housing if rust has formed inside. Tap around the top edge and sides of the cover housing, as necessary.
8. Once the housing is removed, you can visually inspect for surface rust on the support plate. Then remove the 3 support plate screws shown in Figure 4-8 to get to the brake disc pack.

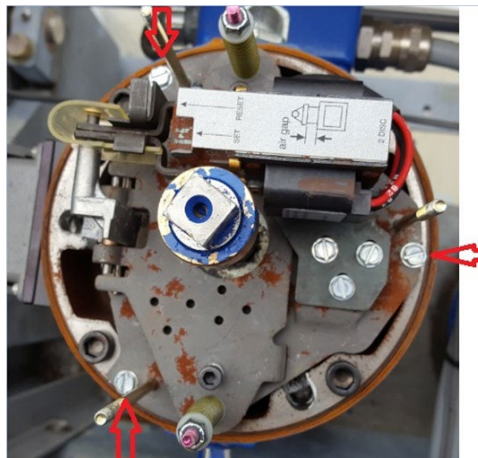

**Figure 4-8: Support Plate Screws**

9. Lift off the support plate and place it aside being cautious to protect the wires to the brake coil from excessive strain. Next, push down on the disc pack to see if the plates move up and down freely (they should move freely as they each ride on springs). You should also visually inspect the 3 cutouts that the disc plates ride up and down in to check for rust or corrosion that could cause them not to move freely.

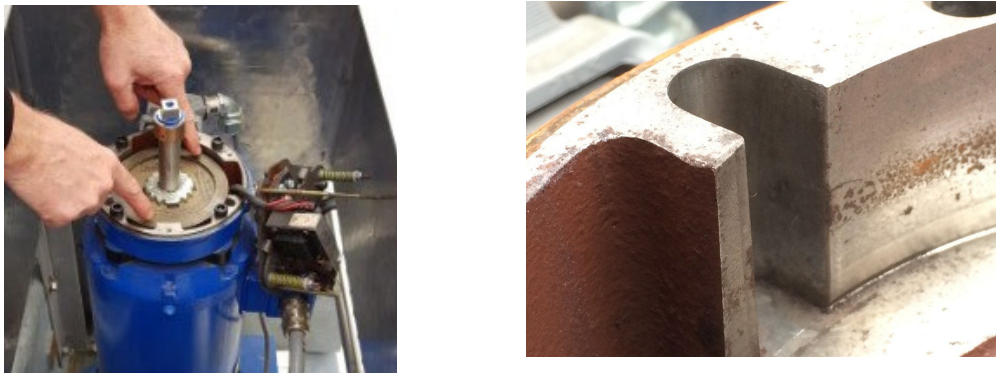

**Figure 4-9: Brake Disc Pack**

10. Remove any surface rust with an emery cloth on only the sides of the tabs on the tabbed discs (with springs) that contact the slot walls. **CAUTION: Be very careful not to break the springs off the disc.** Then use a wood-handled brush with the emery cloth and clean any surface rust from the slot walls (grooves). See Figure 4-10 and Figure 4-11.

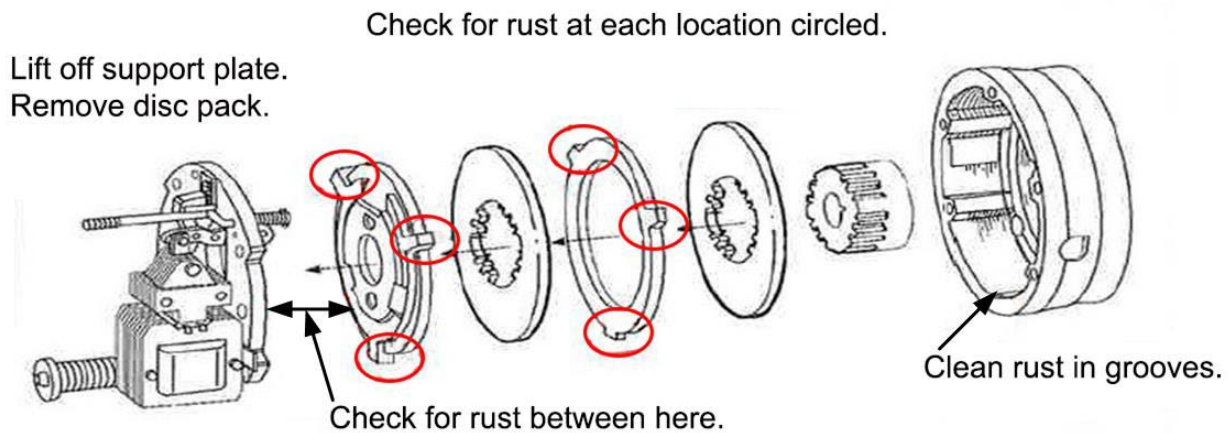

**Figure 4-10: Tabbed Discs - Part 1**

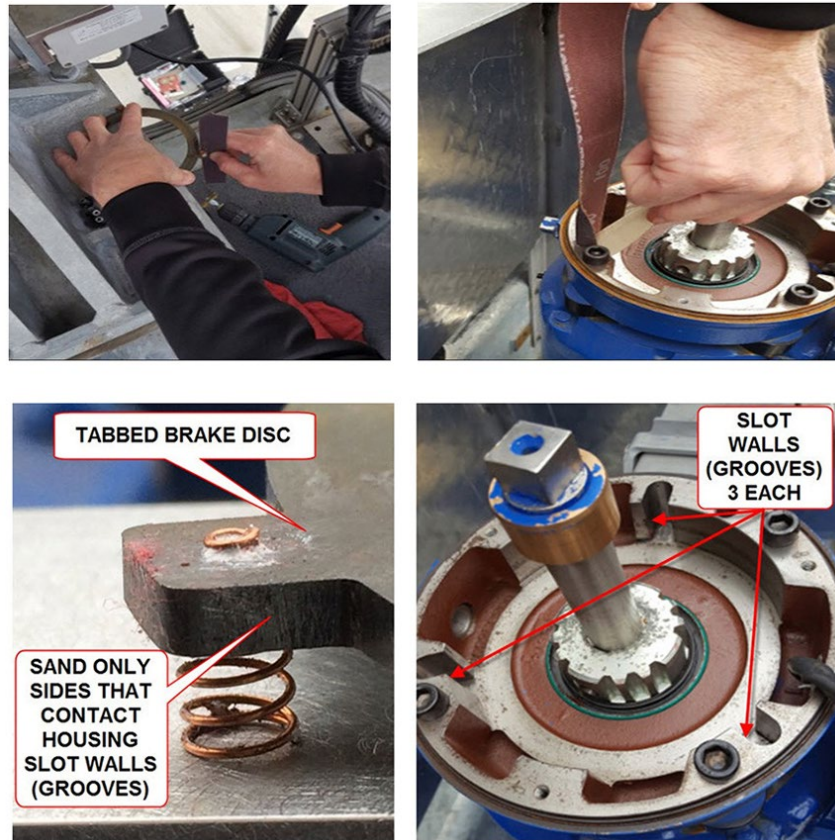
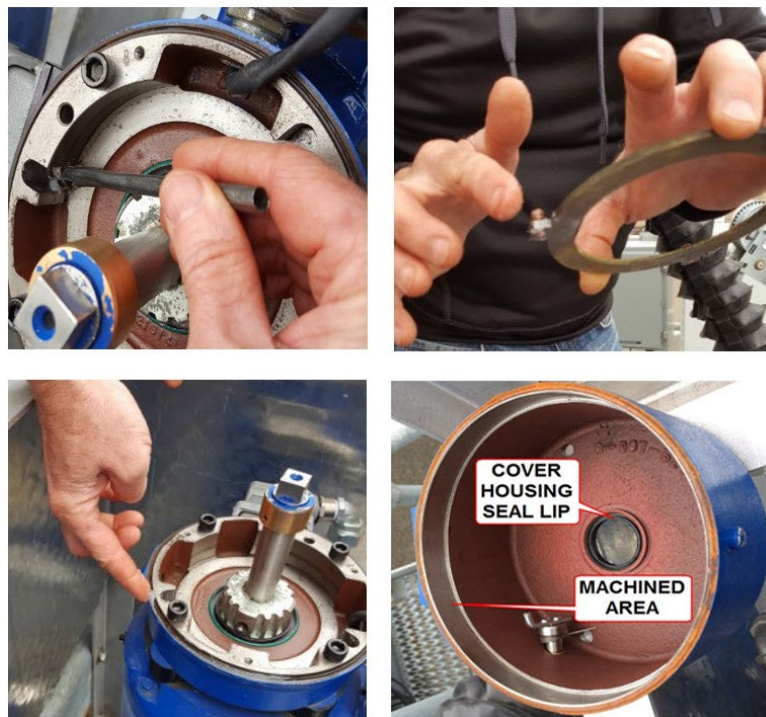

Figure 4-11: Tabbed Discs – Part 2

11. Clean all other surfaces that show rust using the penetrating catalyst spray on a clean rag by the wiping method only. **Note: Do not sand or remove surface rust from any surface of the brake support plate or from the brake disc contacting sides of the tabbed brake discs.** Any surface contamination can be wiped with a clean dry rag and anything remaining should wear off when the brake is used, similar to car brakes. By coating the areas showing surface rust with the penetrating catalyst spray, the surface rust will be deactivated and protected against further surface rust forming. **CAUTION: Do not apply the penetrating catalyst spray or silicone grease to the 2 fiber brake discs. These should ONLY be wiped off with a clean dry cloth as necessary.**

12. Once all surface rust has been cleaned and deactivated, apply silicon grease to the sides of the tabbed brake discs and housing slot walls (grooves). There are 4 areas that need to have the silicone grease applied (see Figure 4-12):

- The disc tab sides that you sanded with the emery cloth.
- The slots in the brake housing that you sanded with the emery cloth (be sure not to get the grease on any other part of the housing, wipe with a rag, if needed).
- The rubber gasket that seals the housing cap.
- The lip of the brake cover housing seal and the machined area.



**Figure 4-12: Applying Silicone Grease**

13. Place the disc pack back into the housing in the same order that you removed it (see Figure 4-10). Note that the spring side of the tabbed discs go toward the motor. The motor shaft should turn freely with only gearing resistance present (i.e., more resistance in the direction the gearing winds up and less in the direction the gearing unwinds). Push down on the disc pack to make sure the disc pack moves up and down freely. See Figure 4-13.

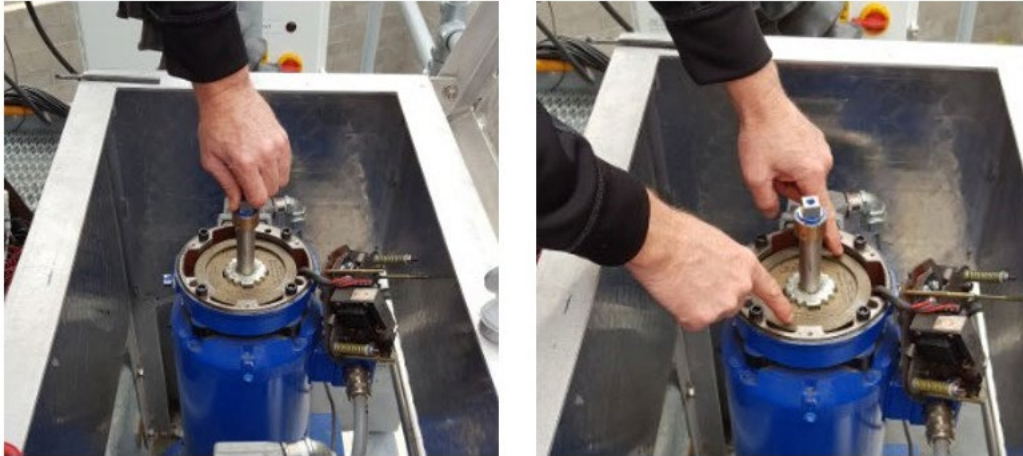

**Figure 4-13: Reinstalling Disc Pack**

14. Reinstall the support plate with the 3 screws that were removed in Figure 4-8 and tighten to 50-55 in-lbs. See Figure 4-14.

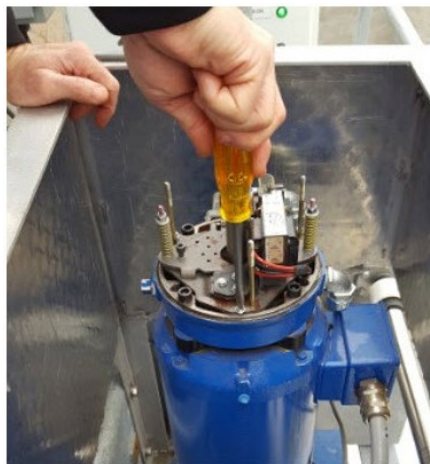

**Figure 4-14: Reinstalling Support Plate**



15. Reinstall the brake housing cover using caution as the brake cover housing seal lips contact the motor shaft. Ensure the rubber sealing washers are on the 3 cap-nuts and tighten them to 50-55 in-lbs or until the rubber sealing washers start to bulge ensuring good sealing.
16. Test whether you can move the square end of the motor shaft on top of the gearmotor with your hand. With the manual brake release lever in the DOWN position, the motor shaft should turn freely with only gearing resistance present (i.e., more resistance in the direction the gearing winds up and less in the direction the gearing unwinds). Alternately, with the lever in the UP position the brake should engage and the square end of the motor shaft should not be able to be rotated.
17. Repeat the steps in this procedure for the other brake ensuring that the manual brake lever on the brake just completed is in the UP position.
18. When both brakes have been completed, ensure that BOTH manual brake levers are in the UP position with the brakes BOTH engaged (i.e., motor shaft not able to be rotated). This is the position for NORMAL operation.
19. Open the Outdoor Unit (ODU) and turn ON the "Logic Power" circuit breaker which restores electrical power to the azimuth brakes and turns the ODU logic system back on.
20. Return the system to service by contacting the Antenna Operations Center and letting them know that you have completed the maintenance procedure.

Inform the Antenna Operations Center that you are ready for them to move the azimuth back and forth several degrees (minimum) to ensure proper axis operation and brake functionality and to remove azimuth axis backlash caused by the maintenance of the azimuth brakes.

Once verified and backlash removed, the Antenna Operations Center can resume mount tracking to peak the antenna signal verifying the full functionality of the mount azimuth.

21. Submit a brief maintenance report with overall results and all photos to Kratos Technical Services.

---

## 5 CORRECTIVE MAINTENANCE & TROUBLESHOOTING

The following sections will offer information, instructions, and guidelines regarding issues of corrective maintenance such as painting, backlash adjustment, and maintenance kits.

### 5.1 TOP 5 ESA MAINTENANCE & TROUBLESHOOTING FAQ

1. What should be done about chips, cracks, scratches, etc., in the paint of the reflector and/or other ESA surfaces?

Priming and/or painting certain surfaces of the ESA is permitted and advisable under specific conditions such as gouges, scratches, etc. in the surface of the reflector paint (refer to Section 9.2 for detailed instructions).

2. How can I remove Backlash?

Backlash is removed by performing anti-backlash Jack Adjustment (for detailed instructions, see Section 9.3)

3. Are there any particular kits available for purposes of maintenance?

A number of maintenance kits are available for this particular antenna. A list of these kits may be found in Table 9-2 (refer to Section 9.4).

4. Are there any particular precautions that can be taken to avoid damaging the feed window?

All Kratos ESA feed windows are rated at .5 psi. This means placing any pressure on the feed window of more than .5 psi is likely to cause permanent damage to the feed window, which will require replacement.

5. What is the proper stow procedure for the 9.4m antenna?

Position the antenna to an Elevation angle above 80° and place the Azimuth Jackscrew in the center of its travel. Please note that stow positioning must be performed before wind speeds reach 65 mph, otherwise the motors may not function.

### 5.2 CORRECTIVE PAINTING INSTRUCTIONS

The following sections offer detailed instructions for corrective painting of particular surfaces on the Earth Station Antenna. Please keep in mind that only qualified personnel should be allowed to perform these procedures. Also, be certain to read all of the following sections thoroughly BEFORE proceeding.

#### 5.2.1 PREPARATORY CLEANING OF ALUMINUM SURFACES

Remove all loose paint and/or rust from the surface to be painted using a scraper, wire brush, or steel wool. If steel wool is used, take care to ensure that none of it is left on the reflector or feed horn window after cleaning (steel wool tends to leave behind particles). Wipe the surface to be painted with acetone using a soft rag. However, keep in mind that the acetone will also dissolve the surrounding paint if used too heavily and/or rubbed too hard. Paint edges can be blended to the metal using very fine grit sandpaper. If necessary, the surface of the reflector may be washed clean using plain water.

**NOTE: Do NOT use bleach, soap, cleaning solutions, or kerosene, as these substances leave behind residue that is difficult to remove.**

### 5.2.2 PRIMING CLEANED ALUMINUM SURFACES

Apply a thin coat (approximately .5 to 1 mil) of primer and feather paint it onto the adjacent painted areas.

Allow the primer to dry thoroughly (4-5 hours, depending on environmental conditions) before applying a finish coat of primer.

Allow the finish coat of primer to dry thoroughly (8-12 hours) before proceeding.

### 5.2.3 PAINTING PRIMED ALUMINUM SURFACES

For antenna surfaces, such as the front or back of the main reflector or subreflector, high-reflectivity white paint should be used. This type of paint disperses light rays. The paint may be applied to the prepared area using a brush, roller, or sprayer. If a sprayer is used, be sure to first thin the paint to a proper consistency with paint thinner (10-15% thinner).

Thoroughly cover all previously primed areas with paint and blend the paint with any preexisting painted surfaces.

### 5.2.4 PREPPING & PAINTING GALVANIZED SURFACES

- Remove all loose paint or rust using a scraper, wire brush, or sanding.
- Wipe clean the surface to be painted with a soft cloth rag and acetone.
- Allow the acetone to dry thoroughly before applying the finish coat of primer.
- Apply a zinc-rich paint as the final finish, thoroughly covering any previously primed surfaces.

### 5.2.5 PRIMING & PAINTING CLEANED JACK SURFACES

Be sure to read ALL of the following instructions/guidelines BEFORE proceeding:

**Surface Preparation** – Use acetone and a soft cloth rag to remove all grease from the surface to be coated.

**Mixing** – Use a power mixer to bring the paint to a uniform consistency before using.

**Thinning** – In the case of Jack Surfaces, thinning the paint is not normally required for most brush, roller, or sprayer applications.

**Using a Brush or Roller** – Using a foam brush, apply paint to surface with full, single strokes. Avoid any re-brushing. Using a medium nap roller, apply paint to surface in long, single rolls. Avoid rerolling. The recommended dry film thickness per coat is 2 mils (50 micron).

**Allow Each Coat to Dry Thoroughly** – Use the below chart (Table 9-1) to determine drying times. These times are based on a 2 mil (50 micron) dry film thickness. Conditions such as higher film thickness, insufficient ventilation, and/or cooler temperatures will likely require cure times to be extended. Allow the primer to dry thoroughly before applying the topcoat. Application of the topcoat should be done based on the above instructions.

**Table 5-1: Cure Times**

TEMPERATURE	TOUCH	HANDLE	TOPCOAT
75° F (24° C)	4 hours (Primer)	12 hours	8 hours
75° F (24° C)	5 Hours (Topcoat)	24 hours	

### 5.3 REMOVING BACKLASH VIA JACK ADJUSTMENT

The backlash removal feature is a factory setting and does not normally require any additional adjustment. However, as time and extended use can lead to the development of wear, it may eventually become necessary to perform a Jac/Jack Anti-Backlash Adjustment in order to reduce/remove backlash.

Use the following procedure for Jac/Jack Anti-Backlash Adjustment:

1. Loosen the Locknut (item b in Figure 9-1).
2. Loosen the Setscrews (item c in Figure 9-1).
3. In order to reduce backlash, rotate the Adjusting Cap (item a in Figure 9-1) in a clockwise direction until able to feel resistance.

**NOTE: Do NOT over-tighten the Adjusting Cap.**

4. Using a felt-tip marker (or equivalent), place a reference mark between the thread on the Adjusting Cap and the Housing.
5. Rotate the Adjusting Cap (item a) in a counterclockwise direction, in an amount equal to Dimension A (labeled "A" in Figure 9-1) on the o.d. of the threads (match Jac/Jack model type, using the chart provided in Figure 9-1).
6. Tighten the Setscrews.
7. While holding the Adjusting Cap (item a) stationary, tighten the Locknut (item b).
8. Operate the Jack through the entire stroke, checking for tight spots.

**NOTE: If Jac/Jack has been used over only a portion of its stroke, the backlash should be adjusted in the least worn portion of the screw.**

**CAUTION: TAKE SPECIAL CARE NOT TO OVER-TIGHTEN THE ANTI-BACKLASH SYSTEM. DOING SO MAY RESULT IN BINDING AND/OR LOCKUP BETWEEN THE DRIVE NUT AND THE LIFTING SCREW. OVER-TIGHTENING CAN ALSO RESULT IN A DESTRUCTIVE HEAT BUILDUP AND/OR OPERATIONAL FAILURE.**

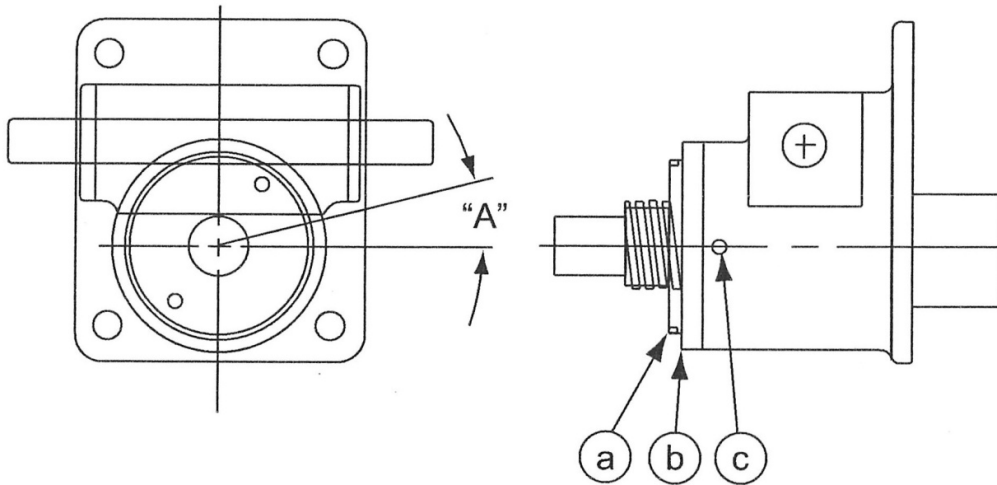

<u>Item</u>	<u>Description</u>	<u>Jac Model</u>	<u>"A" Dim.</u>
a	Adjusting Cap	1 MSJ, 2 MSJ, 2.5 MSJ	7/32
b	Locknut	5 MSJ, 10 MSJ	5/16
c	Set Screw	15 MSJ, 20 MSJ	3/8
		20 MSJ, 30 MSJ	3/8
		35 MSJ	1/2
		50 MSJ	11/16
		75 MSJ	13/16
		100 MSJ	1

**Figure 5-1: Jac/Jack Anti-Backlash Procedure**

## 5.4 MAINTENANCE KITS

The below table provides descriptions of and Kratos part numbers for commonly used maintenance kits:

**Table 5-2: Maintenance Kits**

<b>Part #</b>	<b>Description</b>
<b>221691</b>	Ku-Band Feed Window Replacement Kit
<b>209906-2</b>	9.4m Lubrication & Maintenance Kit

## **6 SITE ACCEPTANCE TEST PROCEDURE**

Once the installation procedure has been completed, and prior to turning over the system to the station facility, some form of Site Acceptance Test procedure will need to be performed, checked off, and signed by the responsible personnel and/or representative.

## **APPENDIX: EQUIPMENT ISSUES & TECHNICAL SUPPORT**

### **REPORTING EQUIPMENT LOSS OR DAMAGE**

If you find that equipment was damaged during the shipping process, file a claim with the carrier. Follow the "Reporting Visible Loss or Damage" or "Reporting Concealed Damage" procedures to file a claim with a carrier.

### **REPORTING VISIBLE LOSS OR DAMAGE**

Make a note of any loss or evidence of external damage on the freight bill or receipt, and have it signed by the carrier's agent. Failure to adequately describe such external evidence of loss or damage may result in the carrier refusing to honor a damage claim. The form required to file such a claim will be supplied by the carrier.

### **REPORTING CONCEALED DAMAGE**

Concealed damage means damage which does not become apparent until the unit has been unpacked. The contents may be damaged in transit due to rough handling, even though the carton may not show external damage. If you discover damage after unpacking the unit, make a written request for an inspection by the carrier's agent, then file a claim with the carrier since such damage is most likely the carrier's responsibility.

### **INVENTORY EQUIPMENT RECEIVED**

After opening your shipment, you should take inventory of the parts immediately. Check each item received in your shipment against the packing slip included with the shipment. If any items are missing, please notify Kratos immediately by contacting Customer Service.

### **RETURNING DAMAGED/DEFECTIVE EQUIPMENT**

Kratos strives to ensure all items arrive safely and in working order. Despite these efforts, equipment is at times received with damage or faults. When this occurs, it may be necessary to return some items to Kratos for either repair or replacement. Returns can be expedited using the following procedure:

Step 1: Call the Kratos Technical Support and request a Return Material Authorization (RMA) number, as well as the address to which you should forward the material(s).

Step 2: Tag or identify the defective equipment, noting the defect or circumstances. Also, be sure to write the RMA number on the outside of the carton. It would be helpful to reference the Kratos sales order and purchase order number, as well as the date the equipment was received.

Step 3: Pack the equipment in the original container with protective packing material. If the original container and packing material are no longer available, pack the equipment in a sturdy corrugated box and cushion it with appropriate packing material.

Step 4: Be sure to include the following information when returning the equipment:

- Company Name, Address (City, State and Zip Code), and Telephone Number
- RMA Number\*

- Problem/Damage Description\*\*
- Contact Name

\* Absence of the RMA number will cause a delay in processing your equipment for repair. Be sure to include the RMA number on all correspondence.

\*\* All installation, adjustment and operational information must be strictly adhered to in order to achieve warranted performance specifications.

Step 5: Ship the equipment to Kratos using UPS, U.S. Postal Service, or other appropriate carrier, freight prepaid and insured. The material should be forwarded to the address given by the Kratos Customer Service contact.

#### TECH SUPPORT CONTACT INFO

For technical support, contact information, and/or technical documentation:

Contact Kratos Global Support.

Email: [support@kratosdefense.com](mailto:support@kratosdefense.com)

Support Lines: US Toll Free: 888.409.9211 | Outside US: 719.472.3411

Address:

Kratos Antenna Solutions Corporation

3801 E. Plano Parkway Suite 200

Plano, TX 75074